

# **OPERATION, PARTS AND SAFETY MANUAL**

**SIGNODE®**

**AM**

**COMBINATION STRAPPING TOOL**

**IMPORTANT!  
DO NOT DESTROY**

**It is the customer's responsibility to  
have all operators and servicemen  
read and understand this manual.**

Contact your local Signode representative  
for additional copies of this manual.

***READ ALL INSTRUCTIONS BEFORE OPERATING THIS SIGNODE PRODUCT***

# **WARNING**

READ THESE INSTRUCTIONS CAREFULLY.

FAILURE TO FOLLOW THESE INSTRUCTIONS CAN RESULT IN SEVERE PERSONAL INJURY.

## GENERAL SAFETY CONSIDERATIONS

### 1. STRAP BREAKAGE HAZARD.

Improper operation of the tool or sharp corners on the load can result in strap breakage during tensioning, which could result in the following:

- A sudden loss of balance causing you to fall.
- Both tool and strap flying violently towards your face.

Failure to place the strap properly around the load or an unstable or shifted load could result in a sudden loss of strap tension during tensioning. This could result in a sudden loss of balance causing you to fall.

- If the load corners are sharp use edge protectors.
- Positioning yourself in-line with the strap, during tensioning and sealing, can result in severe personal injury from flying strap or tool. When tensioning or sealing, position yourself to one side of the strap and keep all bystanders away.

### 2. TRAINING.

This tool must not be used by persons not properly trained in its use. Be certain that you receive proper training from your employer. If you have any questions contact your Signode Representative.

### 3. EYE INJURY HAZARD.

Failure to wear safety glasses with side shields can result in severe eye injury or blindness. Always wear safety glasses with side shields which conform to ANSI Standard Z87.1 or EN 166.



### 4. FALL HAZARD.

Maintaining improper footing and/or balance when operating the tool can cause you to fall. Do not use the tool when you are in an awkward position.

### 5. CUT HAZARD.

Handling strap or sharp parts could result in cut hands or fingers. Wear protective gloves.



### 6. TOOL CARE.

- Inspect and clean the tool daily. Replace any worn or broken parts.
- Lubricate all moving parts weekly.

### 7. WORK AREA.

Keep work areas uncluttered and well lighted.

# **⚠️ WARNING**

Use the correct Signode products for your application. If you need help contact your Signode Representative.

Signode tools and machines are designed and warranted to work together with Signode strapping and seals. Use of non-Signode strap, seals and/or manufactured or specified replacement parts may result in strap breakage or joint separation while applying strapping to a load or during normal shipping and handling. This could result in severe personal injury.

## **JOINT FORMATION**

1. Before using this tool, read its Operation and Safety Instructions contained in this manual.

2. This tool is a double notch type sealer. Each joint must be inspected to make certain it has four (4) good notches. A properly formed joint will appear as shown in the illustration. If the joint does not appear as shown, then the operator must proceed as follows:



A. Make certain that the tool's operating instructions are being followed before applying another strap.

B. Cut the strap off and apply a new strap and seal.

C. An improperly formed seal which does not have four (4) good notches, could result in strap separation. Before moving any package be certain that the seal is formed as shown. Inspect the joint to make certain it appears as shown in the illustration. If not, remove the strap and check the tool for worn or broken parts. Repair the tool before applying another strap.

**NOTE: NOTCHES MUST BE EQUALLY SPACED ALONG THE ENTIRE LENGTH OF THE SEAL. FAILURE TO EQUALLY SPACE THE NOTCHES COULD RESULT IN STRAP SEPARATION.**

## **MOVING AND STACKING STRAPPED LOADS**

Before moving or stacking any strapped load, follow all standard industry practices regarding safe material handling procedures.

## **CUTTING TENSIONED STRAP**

### **FLYING STRAP HAZARD.**

Using claw hammers, crowbars, chisels, axes or similar tools will cause tensioned strap to fly apart with hazardous force. Use only cutters designed for cutting strap. Read the instructions in the cutters manual for proper procedure in cutting strap. Before using any Signode product read its Operation and Safety Manual.

## TABLE OF CONTENTS

	Page
General Safety Information	2
Specifications	4
Operating Instructions	5
Sealing Operation	6
Joint Formation	7
Parts Replacement	8
Maintenance	9
Parts List	10
Troubleshooting	15
Tool Options	17

## **⚠️ WARNING**

Signode tools and machines are designed and warranted to work together with Signode strapping and seals. Use of non-Signode strap, seals and/or manufactured or specified replacement parts may result in strap breakage or joint separation while applying strapping to a load or during normal shipping and handling. This could result in severe personal injury.

When using 3/4 x .031 (19 x 0.79mm) strapping, tool conversion kit, part #306815, must be installed. Failure to install this kit could result in poor performance, component failure or an improperly formed seal which does not have four (4) good notches. See Page 17 for additional information and details.

AM-12, Part No. 023230  
 AM-58, Part No. 023220  
 AM-34, Part No. 023200

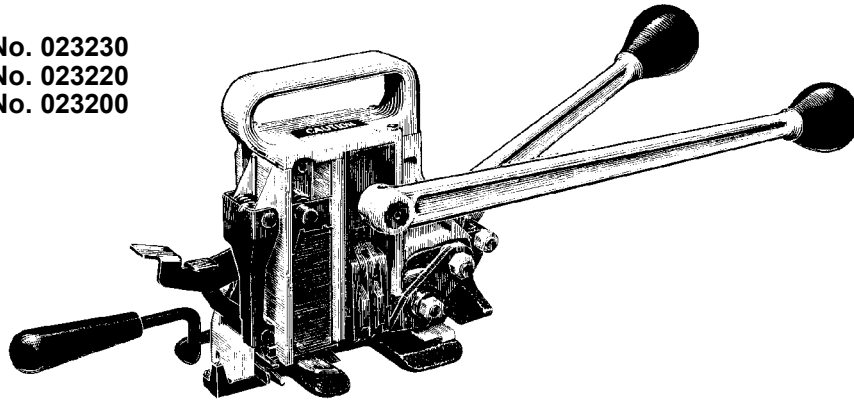

## SPECIFICATIONS

MODEL	TYPE	STRAP		SEALS
		WIDTH	THICKNESS	
AM-12	APEX & MAGNUS	1/2" (12.7mm)	.015" - .023" (.38mm - .58mm)	12AMP
AM-58		5/8" (15.8mm)		58/34AMP
AM-34		3/4" (19.1mm)	.015" - .025" (.38mm - .64mm)	
AM-3431*			.015" - .031" (.38mm - .79mm)	

\* Review Warning information above regarding .031" (.79mm) strapping.

## OPERATING INSTRUCTIONS

### **⚠ WARNING**

Wear safety glasses which conform to ANSI Standard Z87.1 or EN 166.

Stand to one side of the strap while tensioning.  
Make sure all bystanders are clear before proceeding.

Failure to follow the above could result in severe personal injury.

### LOADING SEALS

An extension on the seal pad (61) closes the top strap loading slot as a reminder to add seals. Raise the seal pad assembly and insert a stack of seals in the side of the seal magazine. Make sure the seal stack is pushed all the way in. You may load seals at any time without waiting for seals to run out, because you can break a stack and load as many or as few as you wish.

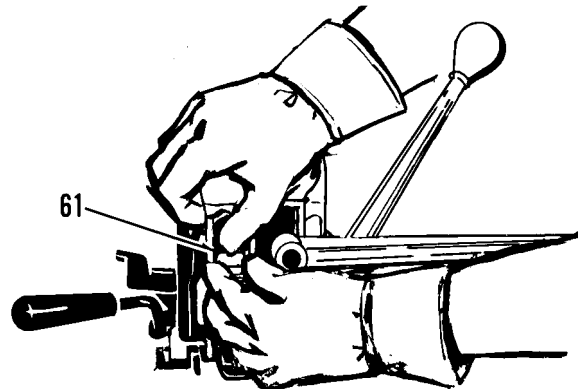

### STRAPPING TIE

1. Encircle the package with the strap and insert the bottom strap-end under the rocking gripper. Push it forward until it contacts the gripper stem. Press the gripper trigger to actuate the holding gripper.

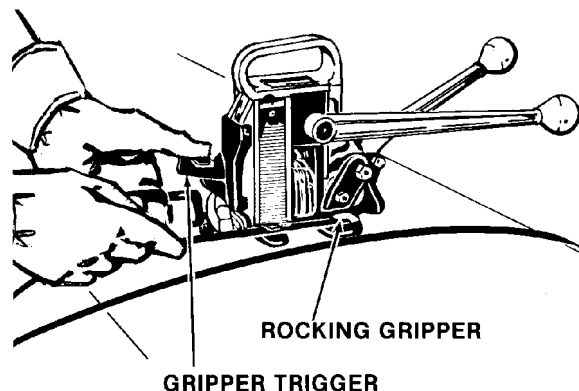
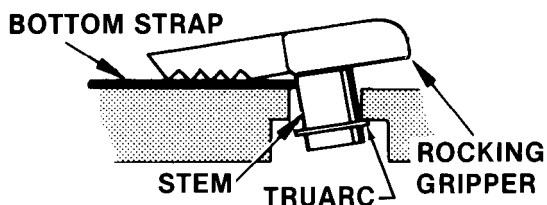

2. Insert the top strap under the feedwheel and insert it sideways into the slot of the strap latch. Pull the excess slack from the strap.

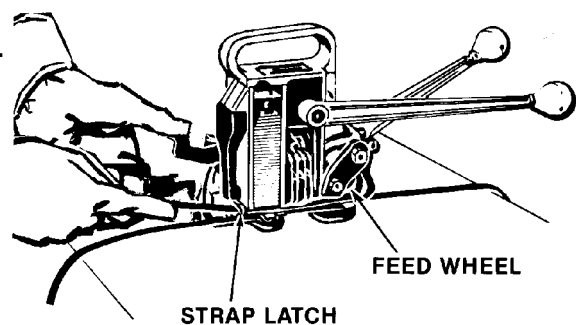

## OPERATING INSTRUCTIONS, Continued

3. While standing to one side of the strapping line, pull the tensioning handle back then push it forward. Repeat this action until the desired tension has been drawn.

Do not push the handle too far forward, as a loss of tension could occur. Note the dotted line in the illustration to the right.

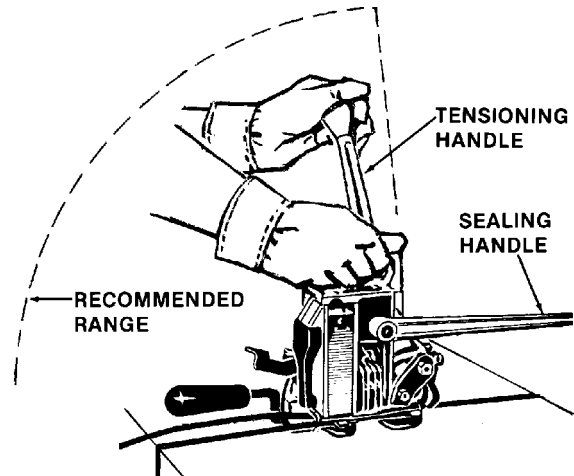

4. Complete the sealing and cut off action by pulling the sealing handle to its full rear position.

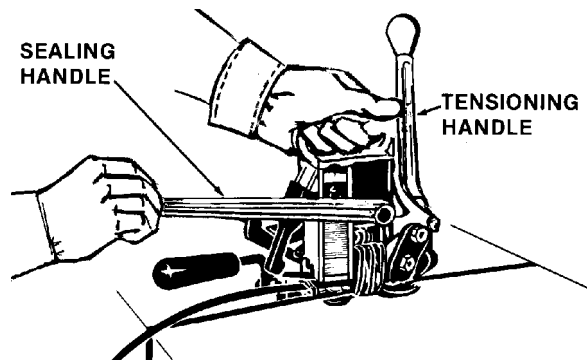

5. To remove the tool from the tensioned strap, return both the tensioning and sealing handles to their forward positions. Place your left hand on the tensioning handle and your right hand on the knob. Swing the rear of the tool to your left until it is free of the strap. Inspect the joint to make sure the tool has properly notched the seal.

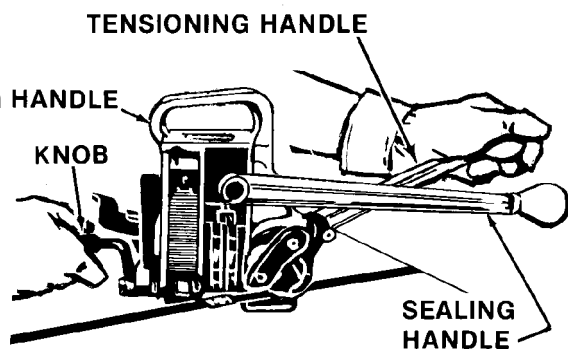

## JOINT FORMATION

# **WARNING**

Before using this tool, read its Operation and Safety Instructions contained in this manual.

This tool is a double notch type sealer. Each joint must be inspected to make certain it has four (4) good notches. A properly formed joint will appear as shown in the illustration. If the joint does not appear as shown, then the operator must proceed as follows:



1. Make certain that the tool's operating instructions are being followed before applying another strap.
2. Cut the strap off and apply a new strap and seal.
3. An improperly formed seal which does not have four (4) good notches, could result in strap separation. Before moving any package be certain that the seal is formed as shown. Inspect the joint to make certain it appears as shown in the illustration. If not, remove the strap and check the tool for worn or broken parts. Repair the tool before applying another strap.

**NEVER HANDLE OR SHIP ANY LOAD WITH IMPROPERLY FORMED JOINTS.** Misformed joints may not secure the load and could cause serious injury. Follow the joint inspection procedures in each sealer's manual.

## **PARTS REPLACEMENT**

### **MAGAZINE AND SEALER MECHANISM**

To disassemble the tool, refer to Figures 8, 9, and 10, and proceed as follows:

1. Remove the seals from the magazine (65) and the sealer jaws.
2. Release the gripper lever (60) by pressing down on the gripper trigger (56).
3. Loosen the cutter adjustment set screw (9).
4. Remove the two magazine screws (6 and 8) on the left side of the sealer frame.
5. Remove the two socket head cap screws (37) from the bottom of the tensioner frame (39).
6. Pivot the rear of the tensioner frame away from the sealer frame and tilt the top of the magazine away from the sealer mechanism and lift the magazine assembly out.
7. Remove the sealer mechanism from the sealer frame.
3. Be sure the strap guide spring (36) is in its proper position in the tensioner frame. Swing the tensioner frame up against the sealer frame and insert and tighten the two socket head cap screws (37) through the tensioner frame.
4. Insert the magazine screws (6 and 8) through the sealer frame and into the magazine. Snug - do not tighten at this time.
5. Move the sealer handle to the vertical position to bring the sealer mechanism to the full down position. Adjust the cutter adjustment screw (9) and tighten both magazine screws (6 and 8).
6. Insert a stack of seals into the magazine. Operate the sealer mechanism through 3 or 4 cycles to check tightness of the cutter adjustment screw and see that the seals feed properly. If the sealer mechanism is excessively tight, back off the cutter adjustment set screw slightly. Next, apply a strap under tension to be sure that all elements of the tool operate properly.

The magazine and the sealer mechanisms are now accessible for examination and replacement of worn or broken parts. The sealer mechanism is serviced by removing the cutter blade (75). Clean all parts. Replace jaws and notchers (76, 77 and 78) as required. Note that the outer jaws can be reversed front to back to provide new cutting edges, thus doubling the life of the parts. After the necessary repairs have been made, grease the parts.

To reassemble:

1. Place the sealer handle in a horizontal position and insert the sealer mechanism. The hook on the sealer cam (89) must be placed over the cam roller (3) in the sealer frame.
2. With the sealer mechanism in place, push down lightly on the sealer handle to keep the sealer mechanism in place and insert the magazine assembly by placing the lower portion of the magazine between the sealer mechanism and the sealer frame. Tip the top forward to bring it into proper alignment.

### **EJECTOR AND EJECTOR LEVER ASSEMBLY**

1. Remove the seals from the magazine (65).
2. Remove the Truarc (49) from the left side of the ejector pin (64).
3. Drive out the ejector pin from the tension handle side.
4. Remove the ejector lever spring (55).
5. Hold the gripper lever (60) down and pull out the ejector lever (50).

To disassemble the ejector:

1. Remove the Truarc (53) from the ejector pin (54).
2. Remove the pin (54), ejector (52), and spring (51). Replace the ejector lever and/or the ejector as necessary.
3. Reassemble with the new ejector by following the above steps in reverse order.



**NOTE:** If only the ejector needs to be replaced, it can be removed without removing the ejector lever by following the above three steps.

To reassemble the ejector lever:

1. Insert the ejector (52) into the cutter block (67) slot. Hold the gripper lever (60) down and slide the ejector lever (50) into position.
2. Start the ejector pin (64) through the right side of the ejector lever and the magazine.
3. Insert the ejector lever spring (55).
4. Insert a punch from the tension handle side to hold the spring in alignment.
5. Tap the ejector pin (64) in from the sealer handle side, removing the aligning punch at the same time.
6. Push on the lower part of the ejector lever (50) to align the holes on the left side of the magazine. Finish tapping in the ejector arm pin (64).
7. Replace the Truarc (49).
8. Insert seals in the magazine.

Operate the sealer mechanism through 3 or 4 cycles to determine that the seals feed properly.

Next, apply a strap under tension to be sure that all elements of the tool operate properly.

#### **FEEDWHEEL (43)**

To change a dirty or worn feedwheel, remove the left-hand threaded nut (47) from the feedwheel shaft (32) and the lock nut (45) from the support shaft (22). With the gear housing (31) in the up position, remove the right-hand washer (25), the side plate (44) and the feedwheel (43). Replace the feedwheel and reassemble the parts in reverse order.

**NOTE:** Inspect side bushing (46) for wear or damage while replacing the feedwheel. Replace the side bushing if necessary.

#### **ROCKING GRIPPER (48)**

Turn the tool on its side. The gear housing should be in the up position. With a pair of Truarc pliers, remove the Truarc (49) from the rocking gripper stem (48).

Push the rocking gripper up and out. Insert a new rocking gripper and reinstall the Truarc.

#### **CUTTER ADJUSTMENT**

If the cutter on the tool does not cut properly, loosen the shoulder bolt (6) and cap screw (8), and adjust set screw (9) to remove clearance between the cutter blade and the cutter block. Adjust with the jaws in the down position. Do not over tighten as the sealing mechanism can be bound by this adjustment. When adjustment has been made, retighten the shoulder bolt and cap screw.

#### **MAINTENANCE**

Clean and apply proper lubrication to all moving parts on a weekly basis. Clean the feedwheel daily with a wire brush (Signode Part No. 023963). Debris accumulated in the teeth of either the feedwheel or the clutch plug must be removed with a small wire brush. A need to clean the teeth will become apparent when either the feedwheel skids on the strap or the lower strap slips on the clutch plug during tensioning.

## TROUBLESHOOTING

The following items are the most common tool symptoms if problems should occur. For symptoms or remedies not shown, contact your Signode service representative for additional information and details. The following tool symptoms are shown in this manual:

- #1 SYMPTOM: Feedwheel slips on top strap during tensioning.
- #2 SYMPTOM: Bottom strap slips out of tool during tensioning.
- #3 SYMPTOM: Strap joints failing after tool removal.
- #4 SYMPTOM: Sealing mechanism crushes or deforms seals.
- #5 SYMPTOM: Tool will not cut off strap after sealing.
- #6 SYMPTOM: Seals do not fully eject and/or cutter blade cuts off seal ends.
- #7 SYMPTOM: Ejector does not pick up seals.

#1 SYMPTOM: Feedwheel slips on top strap during tensioning.	
CAUSE	REMEDY
<ol style="list-style-type: none"> <li>1. Feedwheel teeth packed with dirt or grit.</li> <li>2. Feedwheel teeth worn or chipped.</li> <li>3. Side plate bushing is worn.</li> </ol>	<ol style="list-style-type: none"> <li>1. Clean feedwheel teeth with wire brush.</li> <li>2. Replace the feedwheel.</li> <li>3. Check I.D. of bushing to determine if hole is elongated. Replace if visually elongated.</li> </ol>
<ol style="list-style-type: none"> <li>4. Strap not properly aligned - side plate coming down on strap.</li> </ol>	<ol style="list-style-type: none"> <li>4. Align strap in tool properly.</li> </ol>

#2 SYMPTOM: Bottom strap slips out of tool during tensioning.	
CAUSE	REMEDY
<ol style="list-style-type: none"> <li>1. Rocking gripper teeth packed with dirt or grit.</li> <li>2. Rocking gripper teeth worn or chipped.</li> </ol>	<ol style="list-style-type: none"> <li>1. Clean Rocking gripper teeth with wire brush.</li> <li>2. Replace the rocking gripper.</li> </ol>

#3 SYMPTOM: Strap joints failing after tool removal.	
CAUSE	REMEDY
<ol style="list-style-type: none"> <li>1. Wrong size jaws in tool.</li> <li>2. Low joint strength caused by worn sealer mechanism parts.</li> <li>3. Application related; i.e., strap not strong enough to contain load; load subjected to impact; load expands after being strapped.</li> </ol>	<ol style="list-style-type: none"> <li>1. Check that jaws and tool size match strap size being used.</li> <li>2. Examine sealer mechanism for worn jaws, notchers and pins. Replace as required.</li> <li>3. Review application to determine that strap-seal-tool in use is adequate for application.</li> </ol>

## TROUBLESHOOTING, Continued

<b>#4 SYMPTOM: Sealing mechanism crushes or deforms seals.</b>	
<b>CAUSE</b>	<b>REMEDY</b>
1. Wrong size jaws in tool.	1. Check that jaws and tool size match strap size being used.
2. Strap misaligned.	2. Align strap properly when loading tool.

<b>#5 SYMPTOM: Tool will not cut off strap after sealing.</b>	
<b>CAUSE</b>	<b>REMEDY</b>
1. Cutter blade out of adjustment.	1. Adjust cutter. See Adjustments on page 9.
2. Cutter blade worn.	2. Replace cutter blade.
3. Cutting leg on cutter block worn or broken.	3. Replace cutter block.

<b>#6 SYMPTOM: Seals do not fully eject and/or cutter blade cuts off seal ends.</b>	
<b>CAUSE</b>	<b>REMEDY</b>
1. Broken ejector spring (51).	1. Replace ejector spring.
2. Severely worn tip on ejector (52).	2. Replace ejector.
3. Severely worn cutter blade (75).	3. Replace cutter blade.
4. Bent or cracked ejector lever (50).	4. Check by examining ejector lever for cracks. Replace if bent or cracked.
5. Screws (71) securing cutter block to magazine are loose.	5. Disassemble tool, remove screws. Add one drop of Loctite #242 to each screw and reassemble.

<b>#7 SYMPTOM: Ejector does not pick up seals.</b>	
<b>CAUSE</b>	<b>REMEDY</b>
1. Seals improperly seated in cutter block track.	1. Position seals properly.
2. Dirt in cutter block rear track.	2. Brush dirt out of cutter block rear track.
3. Broken or worn ejector tip.	3. Replace ejector.
4. Screws securing cutter block to magazine are loose.	4. Disassemble tool and tighten screws. Add one drop of Loctite #242 to each screw and reassemble.
5. Broken or bent ejector lever (50).	5. Replace ejector lever.

## TOOL OPTIONS

The following options are available for the AM tools as noted.

### SKID HOOK WITH ADAPTER

All AM tools can be equipped to hang off the side of a load to apply vertical straps. This option frees the operator to use the tool with both hands. The hook can be ordered in varying lengths to place the final strap joint as close as possible to the center of the load.

<u>DESCRIPTION</u>	<u>PART NO.</u>
Skid hook, 8"	005228
Skid hook, 11"	005195
Skid Hook, 15"	005230
Adapter	005595

### AM-3431 CONVERSION, Kit No. 306815

The AM-34 tool can be converted to use 3/4" (19mm) Magnus strap up to .031" (.78mm) thick. AM-34 tools converted to AM-3431 continue to use 34AMP type seals.

## **WARNING**

When using 3/4 x .031 (19 x 0.79mm) strapping, tool conversion kit, part #306815, must be installed. Failure to install this kit could result in poor performance, component failure or an improperly formed seal which does not have four (4) good notches.

The conversion kit contains the following components which are to be substituted for existing components:

<u>KEY</u>	<u>QTY</u>	<u>PART NO.</u>	<u>DESCRIPTION</u>
78	2	306814	Jaw
95	1	015767	Sealer handle
98	1	286369	AM-3431 Nameplate

## SIGNODE NEW TOOL WARRANTY

Signode Engineered Products Warrants that a new Signode strapping tool will operate per functional specifications for a period of sixty (60) days after the date of shipment to the owner's place of business. Normal wearing parts, as outlined in the Operation, Parts & Safety manual, are covered by a thirty (30) day warranty unless, in Signode's judgement, these parts have been subjected to abnormal or extreme usage. Signode's sole liability hereunder will be to repair or replace, without charge, F.O.B. Signode's Glenview, Illinois plant, any tool which proves to not operate per functional specifications within the stated period. Signode reserves the right to replace any tool which proves not to operate per functional specifications with a new or like-new tool of the same model if in Signode's judgement such replacement is appropriate. Any new replacement tool provided to an owner will carry a full sixty (60) day warranty. Any warranty repaired tool or like-new replacement tool will carry a warranty for the balance of the time remaining on the initial sixty (60) day warranty. This warranty will be extended to compensate for the time the tool is in Signode's possession for warranty repairs.

This warranty is void as to any tool which has been: (I) subjected to mis-use, misapplication, accident, damage, or repaired with other than genuine Signode replacement parts, (II) improperly maintained, or adjusted, or damaged in transit or handling; (III) used with improperly filtered, unlubricated air or improper strapping material, (IV) in Signode's opinion, altered or repaired in a way that affects or detracts from the performance of the tool.

**SIGNODE MAKES NO WARRANTY, EXPRESSED OR IMPLIED, RELATING TO MERCHANTABILITY, FITNESS OR OTHERWISE EXCEPT AS STATED ABOVE AND SIGNODE'S LIABILITY AS ASSUMED ABOVE IS IN LIEU OF ALL OTHERS ARISING OUT OF OR IN CONNECTION WITH THE USE AND PERFORMANCE OF THE TOOL. IT IS EXPRESSLY UNDERSTOOD THAT SIGNODE SHALL IN NO EVENT BE LIABLE FOR ANY INDIRECT OR CONSEQUENTIAL DAMAGES INCLUDING, BUT NOT LIMITED TO, DAMAGES WHICH MAY ARISE FROM LOSS OF ANTICIPATED PROFITS OR PRODUCTION, SPOILAGE OF MATERIALS, INCREASED COSTS OF OPERATION OR OTHERWISE.**

Considerable effort has been made to ensure that this product conforms to our high quality standards. However, should you experience any difficulties, please contact your Sales Representative providing samples and the manufacturing code specified on the tool.

PART #	DESCRIPTION	AREA OF USE
<b>LUBRICANTS</b>		
177029	GEAR HOUSING GREASE	CLUTCH DRIVES, INTERNAL GEARS, GEAR SETS
422792	WHITE LUBRIPLATE GR-132 GREASE	PNEUMATIC PARTS, AIR CYLINDERS, AIR VALVES, O-RINGS
422793	BLACK LUBRIPLATE 3000W GREASE	MOVING INTERNAL PARTS, JAWS, LINKS
432322	EP ACCROLUBE GREASE	HIGH FRICTION CONTACT PARTS
008556	LS-1236 AIR LINE OIL	AIR MOTORS, AIR VALVES
<b>ADHESIVES</b>		
422794	LOCTITE #222, PURPLE	LOW STRENGTH, SCREWS 1/4" (6MM) OR SMALLER SIZES
422795	LOCTITE #242, BLUE	MEDIUM STRENGTH, SCREWS 5/16" (8MM) OR LARGER SIZES
422796	LOCTITE #271, RED	HIGH STRENGTH, SEMI-PERMANENT SCREW APPLICATION
422797	LOCTITE #609, GREEN	PERMANENT, CURVED SURFACE PART CONTACT
274111	LOCTITE #380, BLACK MAX	PERMANENT, FLAT SURFACE PART CONTACT
<b>CLEANING BRUSHES</b>		
023963	SMALL BRUSH	FEEDWHEEL & GRIPPER TEETH
269589	LARGE BRUSH	FEEDWHEEL & GRIPPER TEETH