

DEUTSCH	3
ENGLISH	17
FRANÇAIS	31
ITALIANO	45

<b>BETRIEBSANLEITUNG UND SICHERHEITSVORSCHRIFTEN</b>
<b>OPERATING AND SAFETY INSTRUCTIONS</b>
<b>MODE D'EMPLOI ET DE SÉCURITÉ</b>
<b>ISTRUZIONI PER L'USO E DI SICUREZZA</b>

## CR 24 A

Ab Serie-Nr. 1000

From serie no 1000

A partir du no de série 1000

A partire dal no. di serie 1000

Handgerät zum Umreifen mit Stahlband

Hand tool for steel strapping

Appareil pour le cerclage par feuillard d'acier

Apparecchio per reggiare con reggetta d'acciaio



Vor dem Gebrauch des Gerätes die Betriebsanleitung aufmerksam lesen.

Before using the tool, read the operating instructions carefully.

Avant l'utilisation de l'appareil, consultez soigneusement le mode d'emploi.

Prima d'utilizzare l'apparecchio, leggere attentamente le istruzioni per l'uso.

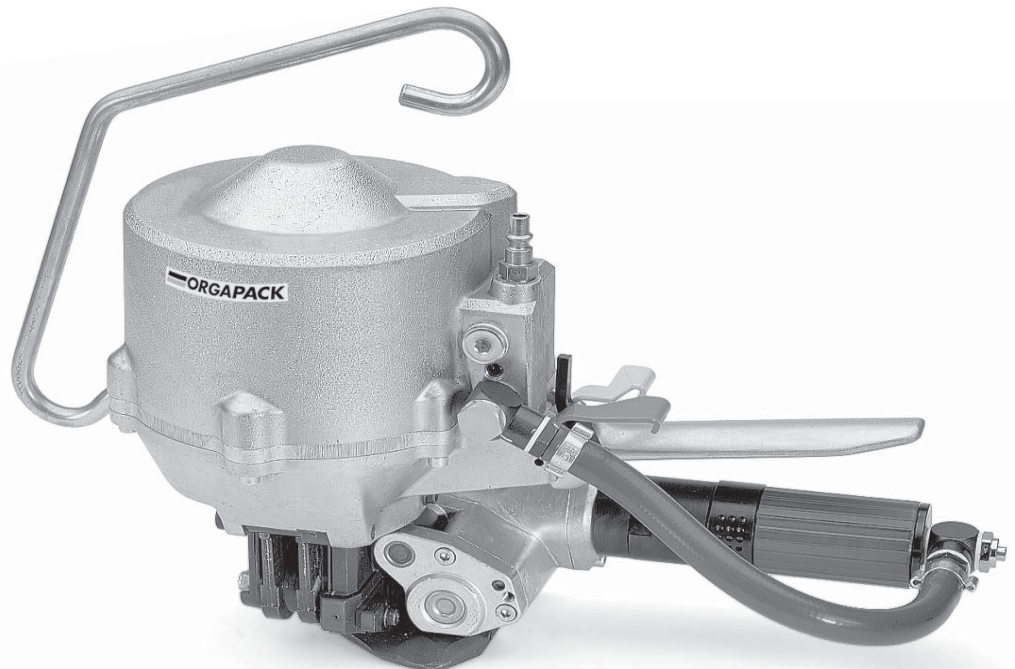

**PACKAGING**

888-922-1622

WWW.IPACK.COM

## TABLE OF CONTENTS

	Page
<b>1 Technical data</b>	<b>17</b>
<b>2 General information</b>	<b>18</b>
2.1 Information on environmental protection	18
<b>3 Safety instructions</b>	<b>19</b>
<b>4 Description</b>	<b>20</b>
4.1 Design	20
4.2 Function	20
<b>5 Initial operation</b>	<b>21</b>
5.1 Suspending the tool	21
5.2 Compressed-air connection	21
<b>6 Operating instructions</b>	<b>22</b>
6.1 Operating the tool	22
<b>7 Preventive and corrective maintenance</b>	<b>24</b>
7.1 Adjusting tensioning force/tensioning speed	24
7.2 Setting clearance between tension wheel and tension plug	24
7.3 Replacing tension wheel	24
7.4 Replacing jaws and notcher	25
7.5 Cleaning the tool	25
<b>8 Parts list</b>	<b>26</b>
Explosion drawing	28
<b>9 Parts list compressed air motor</b>	<b>29</b>
Explosion drawing	30

## 1

## TECHNICAL DATA

Weight	7,6 kg (16.6 lbs)
Dimensions	Length 420 mm (16.5") Width 160 mm (6.3") Height 300 mm (11.8")
Tension force	Up to approx. 7000 N
Tension speed	65 mm/s (2.56"/s)
Air pressure	Maximum 6 bar static
Air consumption	
– Tensioning	6.4 NI/s
– Sealing	12 NI
Air connection	G 1/4" (1/4" NPT)
Sealing	Sealjoint with double notch
Emission sound pressure levels, measurement type A (EN ISO 11202)	$L_{pA}$ 76 dB (A)
Vibrations at handle (EN ISO 8662-1)	$a_{h,w}$ < 2,5 ms <sup>-2</sup>
<b>STEEL STRAP</b>	
Strap width	19 mm (3/4")
Normal quality: Strap thickness	0.60–0.80 mm (.023"–.031")
Tensile strength	Up to approx. 850 N/mm <sup>2</sup> (120'000 lbs/in <sup>2</sup> )
High strength quality: Strap thickness	0.60–0.80 mm (.023"–.031")
Tensile strength	Up to approx. 1100 N/mm <sup>2</sup> (157'000 lbs/in <sup>2</sup> )
<b>SEALS</b>	
Strap width 19 mm	CSP 617

## DECLARATION OF AGREEMENT

We take sole responsibility for declaring that the tool CR 24 A, to which this declaration refers, is in full compliance with the current requirements of the guidelines laid down by the council on 22th June 1998 (98/37/EEC), "Machine Guidelines".

According to norm:  
EN 292-1, EN 292-2, EN 349, EN 983, EN 1050  
prEN 792-2

CH-8953 Dietikon, June 2001

Manager  
Sales & Marketing:

Manager  
Engineering:



R. Kieffer



M. Binder

# 2

## GENERAL INFORMATION

These operating instructions are intended to simplify familiarisation with the strapping tool and the possibilities of application for the intended purpose. The operating instructions contain important information concerning the safe, proper and efficient use of the strapping tool. Observation of the information will help to avoid danger, reduce repairs and stoppages and increase the reliability and service life of the strapping tool.

The operating instructions must always be available at the place of operation of the strapping tool. They must be read and observed by all persons concerned with work on the strapping tool. This work specifically includes operation, refilling of operating material, fault elimination and maintenance.

In addition to the operating instructions and the regulations for accident prevention effective in the country of use and place of application, the recognised technical regulations for safety and proper working must also be observed.



### CAUTION!

Used where there is danger to life and health.



### WARNING!

Used for danger which can cause material damage.

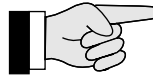

### NOTE!

Used for general information and information which if not followed can cause faults in the operating sequence.

### 2.1 INFORMATION ON ENVIRONMENTAL PROTECTION

This tool is manufactured without any physical or chemical substances which could be dangerous to health. For disposal of all the parts, the governmental instructions must be observed.

# 3

## SAFETY INSTRUCTIONS



**Inform yourself!**  
Read the operating instructions carefully.



**Do not use a bottled air or gas source!**  
Do not operate this tool by using a bottled air or gas source.



**Protect yourself!**  
When operating the tool, wear eye, face and hand protection (cut-proof gloves).

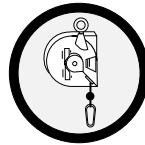

**Caution:**  
For suspending the tool, only spring balancers which conform to the safety regulations should be used.



**Warning:**  
**Strap will snap forward!**  
When cutting the strap, hold the upper portion and stand safely away from the strap.  
**Caution:**  
The lower strap will snap forward.



**Original ORGAPACK seals must be used exclusively.**



**Warning:**  
**Strap could break!**  
Do not stand in line with the strap while it is tensioned. The strap could break!



**Original ORGAPACK spare parts must be used exclusively!**  
Not using original spare parts will dissolve the warranty and the liability.



**Caution:**  
**Danger of squeezing!**  
Do not put your fingers into the tension wheel area.

**Use for the intended purpose**

The tool is intended for strapping heavy round packages, bundles of sectional steel, pipes etc.

This tool was designed and manufactured for safe handling during the strapping operation.



**Caution:**  
**Only strap packed goods!**  
Do not put hands or other parts of the body between the strap and the package during the strapping process.

The tool processes steel straps only.

**Possible misuse**

The use of plastic straps is not possible.



**Do not exceed the air pressure!**  
Do not exceed the recommended air pressure.

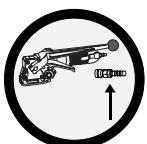

**Use safety coupling!**  
For connecting the air hose to the tool, use only a safety coupling.

# 4

## DESCRIPTION

### 4.1 DESIGN

- 1 Compressed air connection
- 2 Yellow button (Sealing)
- 3 Green button (Tensioning)
- 4 Handle
- 5 Compressed air motor
- 6 Pressure reducing valve
- 7 Tension wheel and tension plug
- 8 Base plate
- 9 Sealing jaws
- 10 Compressed air cylinder
- 11 Suspension bow

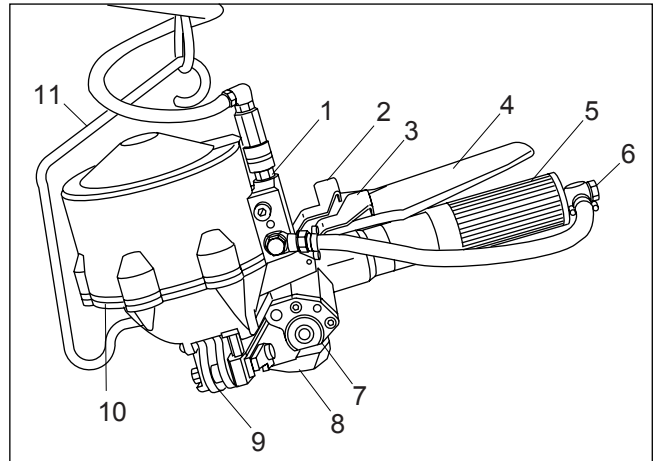

Fig. 1

### 4.2 FUNCTION

- Feed the strap manually through the seal (2/1).
- Bend the strap start (2/5).
- Tensioning by feed wheel principle (2/4).
- Sealing by notching (2/2) the seal.
- Strap cut with knife (2/3).

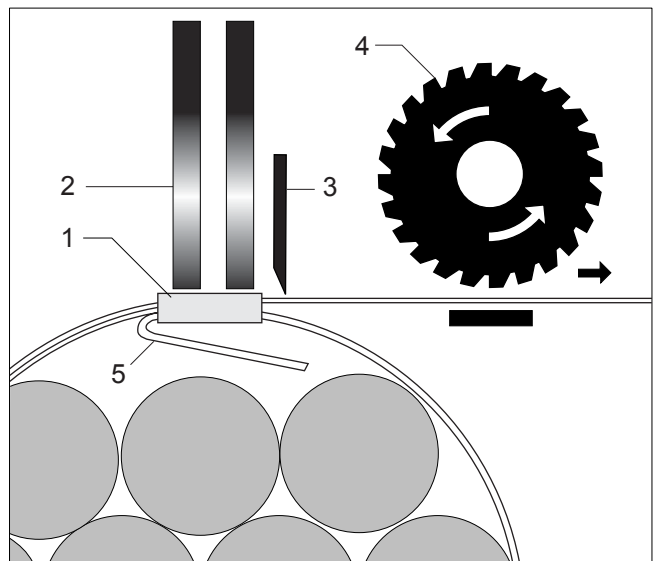

Fig. 2

# 5

## INITIAL OPERATION

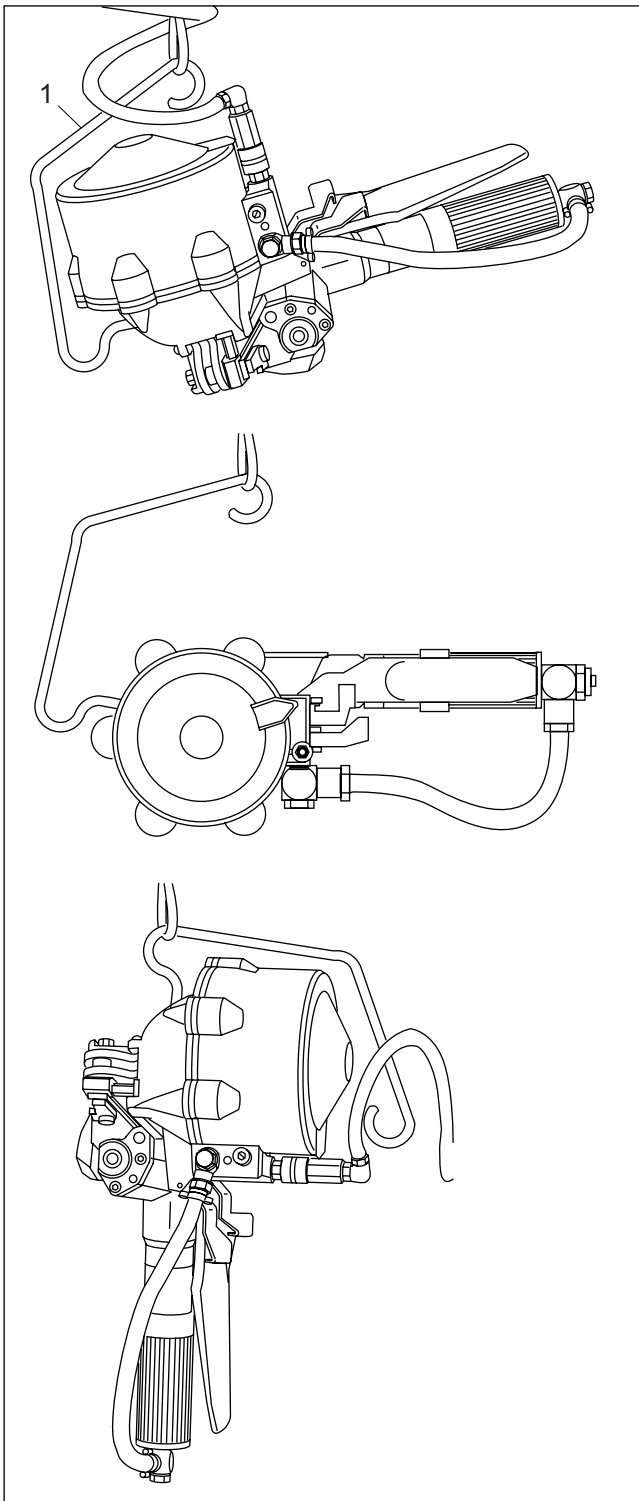

Fig. 3

### 5.1 SUSPENDING THE TOOL

The tool is equipped with a universal suspension bow (3/1). It can be suspended on a spring balancer. The suspension bow is designed to strap the package horizontal, vertical or side ways.

### 5.2 COMPRESSED-AIR CONNECTION

Motor and sealing piston are lubricated by oil mist of the compressed air. Properly prepared compressed air is therefore essential for trouble-free operation of the tool. This can only be ensured by a reliably functioning maintenance unit, consisting of water separator, pressure reducing valve with pressure gauge and oil mist lubricator.

The oil mist lubricator should supply sufficient oil. The length of the hose between the CR 24 A and the maintenance unit should not exceed 5 m (15 ft). The internal diameter of the pipe should be at least 10 mm ( $\frac{3}{8}$ "). It must be ensured that the hose does not form loops, where oil can collect.

# 6

## OPERATING INSTRUCTIONS

### 6.1 OPERATING THE TOOL

- Draw the strap from the dispenser, slide the strap through the seal (4/1) and wind strap around the package.
- Push the strap start a second time through the seal.
- Bend the strap start (4/2) below the seal 3–4 cm (1–2").
- Pull the strap tightly by hand and take a portion of the strap leading to the dispenser with the left hand approx. 20 cm (8") away from the seal.
- Hold the handle (5/1) of the tool in the right hand and raise the motor up to the stop.
- Insert the strap below the tension wheel completely into strap guide. At the same time push the tool forward against the seal.
- Release the motor.

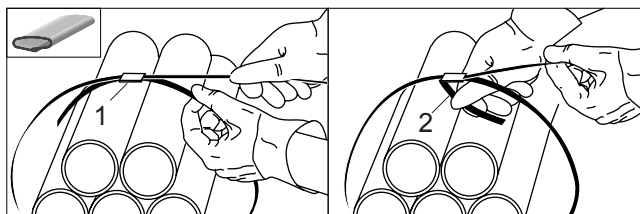

Fig. 4

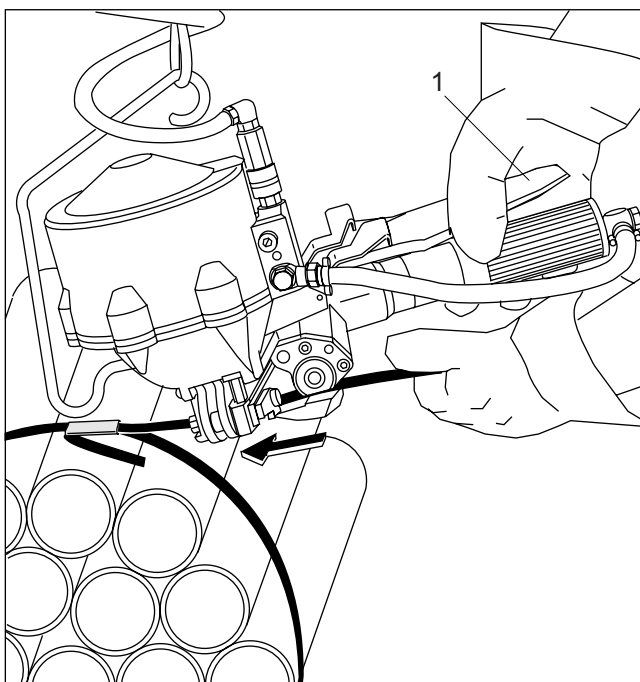

Fig. 5

### Tensioning

- Press the green button (6/1) completely down with the thumb of the right hand, until the required strap tension is reached.



The maximum tensioning force can be infinitely adjusted (see chapter 7.1).

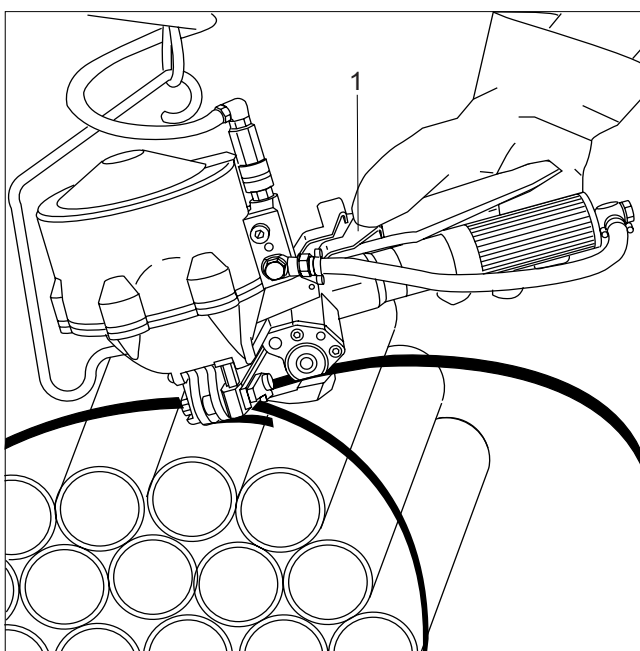

Fig. 6

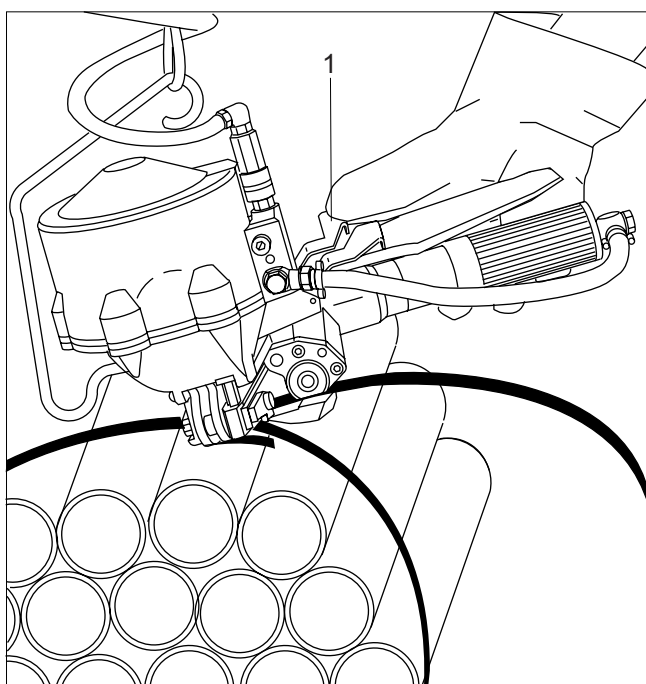

Fig. 7

### Sealing

- Press the yellow button (7/1) with the right thumb until the seal is notched and the strap is cut off.

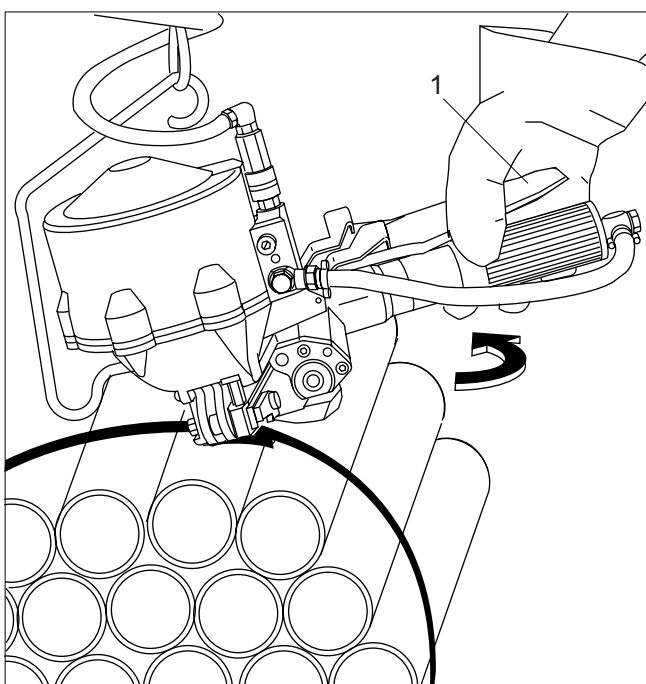

Fig. 8

- Raise the motor up to the handle (8/1) and swivel the tool away from the strapping to the right at the rear.

### Check of seal

To obtain the maximum seal efficiency, the notches have to be cut properly into the seal. If these notches are not correctly cut, replace jaws and notcher (see chapter 7.4).



# 7

## PREVENTIVE AND CORRECTIVE MAINTENANCE

### 7.1 ADJUSTING TENSIONING FORCE/ TENSIONING SPEED

- Set air pressure at pressure reducing valve of maintenance unit to 4–6 bar.
- With a screwdriver adjust pressure reducing valve (9/1) of air motor, so that the motor stops when the required tension is reached. It should be ensured that the seal is notched properly and that the strap is cut off.

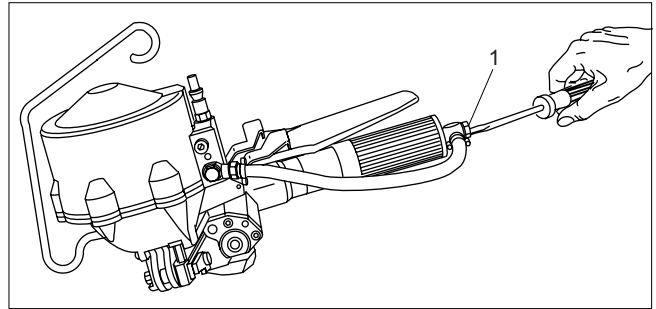



Fig. 9

### 7.2 SETTING CLEARANCE BETWEEN TENSION WHEEL AND TENSION PLUG

 The tension wheel and the tension plug must not touch (damage the teeth). If the spacing is too great, the strap slips through before the final tension is reached.

- Disconnect tool from air supply.
- Loosen set screw (10/1).
- Set tension plug (10/2) with screwdriver, so that the clearance between tension wheel and tension plug is 0.1–0.25 mm (.0039"–.0098"). Turning clockwise decreases the clearance, turning counterclockwise increases the clearance.
- Turn tension plug so that a notch of the tension plug points in the direction of the set screw (10/1).
- Tighten set screw (10/1).
- Check clearance, reset if necessary.

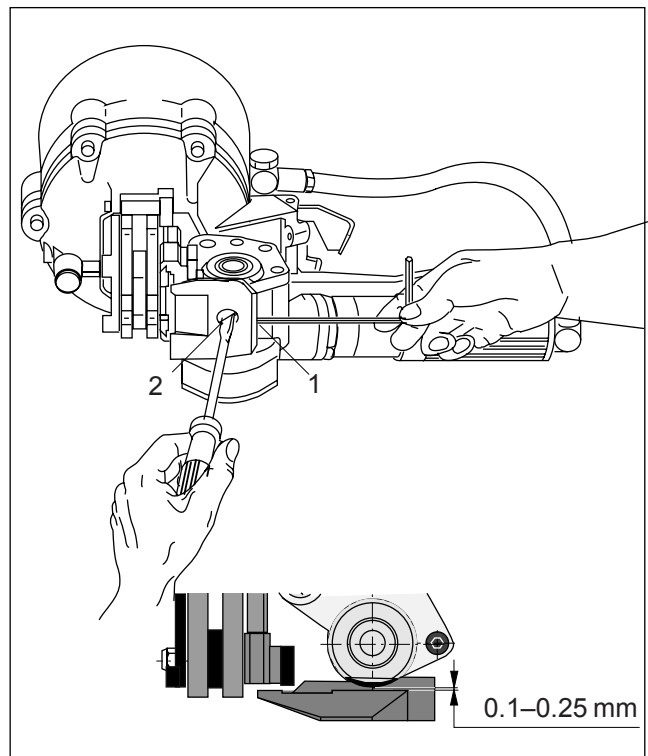



Fig. 10

### 7.3 REPLACING TENSION WHEEL

 If the tension wheel spins before the required strap tension is reached, the tension wheel must be replaced (precondition: clearance set correctly, see chapter 7.2).

#### Removal

- Disconnect tool from air supply.
- Remove two cylinder screws (11/1).
- Carefully remove bearing plate (11/2) from tension shaft.
- Remove counter washer (11/3) and tension wheel (11/4). Replace tension wheel.

#### Installation

- Install the parts in reverse order.
- Secure cylinder screws (11/1) with Loctite 243.
- Set clearance between tension wheel and tension plug (see chapter 7.2).

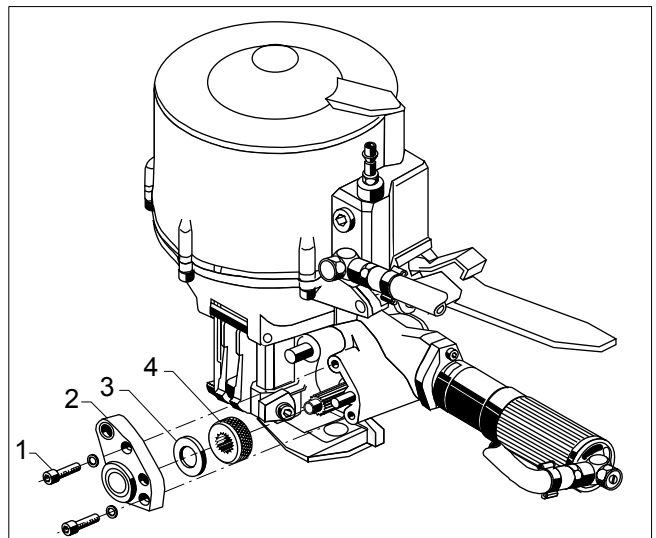

Fig. 11

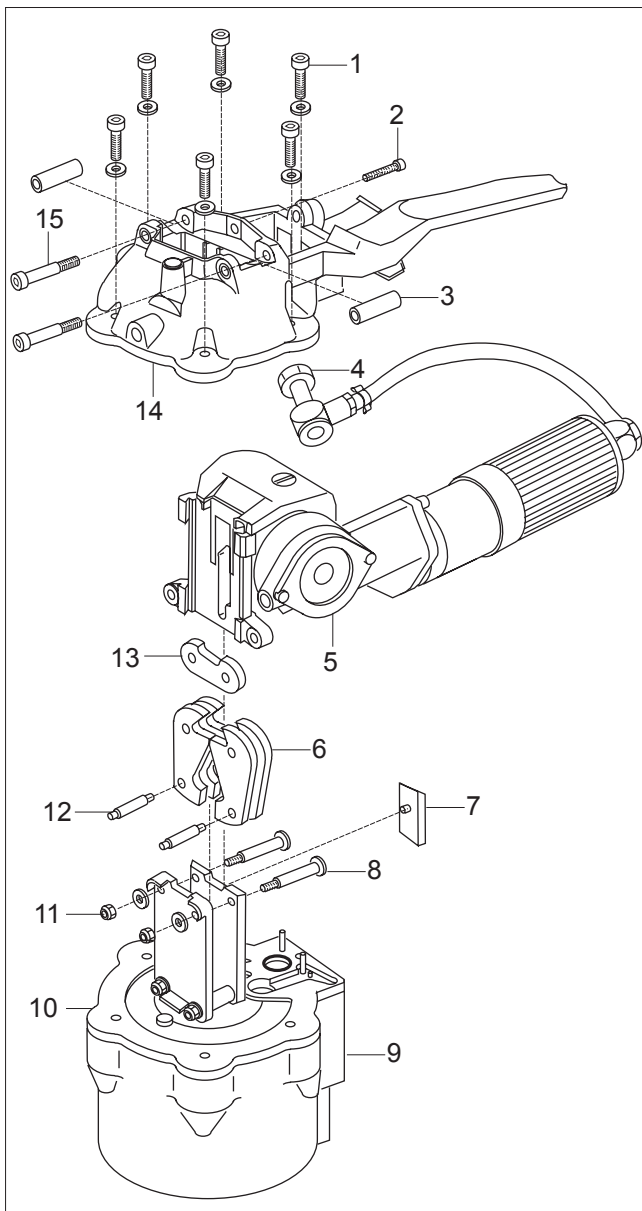
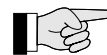

Fig. 12

#### 7.4 REPLACING JAW AND NOTCHER

##### Removal

- Disconnect tool from air supply.
- Mount the tool on the cylinder (12/9) carefully into a vice.
- Remove hollow screw (12/4) and remove air hose.
- Loosen two shoulder screws (12/15) and one cylinder screw (12/2). Remove bushings (12/3). Slide tension unit with base plate (12/5) carefully up.
- Remove cutting knife (12/7).
- Remove six cylinder screws (12/1) and remove housing (12/14).



During removal of the tool, it must be ensured, that the retaining ring (12/10) remains on the cylinder (12/9).

- Loosen two lock nuts (12/11) and remove bolts (12/8).
- Swivel down the jaws (12/6) and remove bolts (12/12).
- Remove and replace jaws and notcher.

##### Installation

- Install the parts in reverse order.

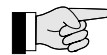

Mount new lock nuts (12/11). After mounting the nuts, the bolt (12/8) must still be turning. Secure shoulder screw (12/15) and hollow screw (12/4) with Loctite 243.

#### 7.5 CLEANING THE TOOL

- The tool should be regularly cleaned. Especially the tension wheel and the jaw unit should be kept clean. The easiest way to do this, is to use compressed air and to blow out the dust (wear eye protection).

## 8

## PARTS LIST 1174.400.000/7

When ordering please indicate part number and quantity

Explosion drawing see page 28

**\* Recommended spare parts**

Pos.	Part no	Part name	Quantity
1	1174.400.056	Cylinder	1
2			
3			
4			
5			
6	1174.400.057	Retaining ring	1
7	1820.020.281	Washer	1
8	1174.400.058	Housing incl. pos. 9+10	1
9	1935.510.100	Radial slide bearing, ø 10/12 x 10	1
10	1935.000.200	Internal ring, ø 9/12 x 12	1
11			
12	1174.400.067	Silencer	1
13	1174.400.075	Gear housing incl. Pos. 14	1
14	1937.310.103	Cylinder bearing, ø 10/14 x 10	2
15			
16			
17	1174.400.050	Cover	1
18	1174.400.051	Flange	1
19			
20	1174.400.072	Bearing plate , incl. Pos. 14	1
21			
22			
23	1174.400.060	Piston	1
24	1174.400.059	Base plate	1
25			
26	1831.021.011	Plate front	1
27	1174.400.063	Plate rear	1
28	1174.400.061	Slider	1
* 29	1174.400.066	Jaw	4
* 30	1174.400.064	Notcher	1
31	1174.400.065	Link	2
32			
33	1934.450.060	Counter washer, ø 6/13 x 2	4
34	1820.030.444	Bolt	1
35	1821.033.008	Bolt	4
* 36	1820.030.439	Bolt	2
37	1820.020.278	Bushing	2
38	1916.306.062	Lock nut, M 6	4
39			
* 40	1174.400.073	Cutter, incl. pos. 41	1
41	1921.803.062	Roll pin, ø 3 x 6	1
42			
43	1927.613.820	O-Ring, ø 138 x 2	1
44	1927.601.410	O-Ring, ø 14 x 1,5	1
45	1928.011.400	K-Ring, ø 140	1
46	1820.020.277	Washer	2
47			
48	1916.308.082	Lock nut, M 8	1
49			
50			

Pos.	Part no	Part name	Quantity
51	1820.100.032	Bushing	1
52	1820.010.047	Compression spring conical	1
53	1925.010.802	Ball, ø 8	1
54	1820.100.041	Valve stem short	1
55	1927.601.600	O-Ring, ø 16 x 1	6
56	1820.100.031	Bushing	1
57	1927.600.420	O-Ring, ø 4 x 2	1
58			
59			
60			
61	1821.010.001	Compression spring	1
62	1820.100.039	Ring	1
63	1820.100.042	Valve stem long	1
64			
65	1927.600.820	O-Ring, ø 8 x 2	5
66	1820.100.038	Sleeve	2
67	1820.100.037	Sleeve	1
68			
69	1927.600.600	O-Ring, ø 6 x 1	3
70	1927.601.710	O-Ring, ø 17 x 1,5	1
71			
72	1174.400.071	Shaft	1
73	1174.400.054	Bushing	1
* 74	1820.040.108	Tension wheel	1
75	1934.430.120	Counter washer, ø 12/26 x 0.8	2
76	1934.012.120	Needle bearing, ø 12/18 x 12	3
77	1921.306.220	Straight pin, ø 6m6 x 22	1
78			
79	1821.070.001	O-Ring, ø 3,5 x 1,5	1
80			
81			
82	1933.722.162	Needle bearing, ø 22/28x 16	3
83	1934.310.200	Thrust bearing, ø 20	1
84	1934.430.200	Counter washer, ø 20/35 x 0.8	1
85	1820.060.088	Gearwheel	1
86	1820.060.089	Gear	1
87	1174.400.070	Shaft	1
88	1933.725.120	Free wheel, ø 25/32 x 12	1
89	1934.330.171	Needle bearing, ø 17/30 x 6	1
90			
91			
92			
93			
94	1894.422.000	Air motor, LZB 33 A 005-63	1
95	1895.312.003	Woodruff key	1
96			
97			
98			
99			
100			
101	1913.606.502	Shoulder screw, ø 8/M 6 x 50	2

Pos.	Part no	Part name	Quantity
102	1820.020.279	Bushing	2
103			
104			
105	1820.030.442	Locking screw	1
106	1925.210.042	Saucer spring (14 pieces), ø 8/4.2 x 0.4	1
107	1820.030.441	Bolt	1
108	1925.010.702	Ball, ø 7	1
109	1820.030.443	Set screw	1
110	1174.400.069	Roll	1
111	1174.400.068	Suspension bow	1
112			
113			
114	1174.400.076	Lever green	1
115	1174.400.077	Lever yellow	1
116			
117	1174.400.078	Shaft	1
118	1920.103.062	Lock washer, ø 3,2	2
119			
120			
121			
122			
123			
124			
125	1174.400.079	Pawl	1
126			
127			
128	1911.305.162	Cylinder screw, M 5 x 16	3
129	1911.005.258	Cylinder screw, M 5 x 25	6
130	1911.005.168	Cylinder screw, M 5 x 16	4
131			
132	1919.605.062	Lock nut, M 5	12
133			
134			
135			
136			
137	1820.010.144	Compression spring	1
138			
139			
140	1941.112.720	L-Connection, G 1/4"	2
141	1941.111.040	Hose connection, G 1/4"	2
142	1940.070.723	One-way restrictor, G 1/4"	1
143			
144			
145	1941.210.720	Gasket, G 1/4"	7
146	1940.331.188	Hose clamp, ø 18	2
147	1941.202.722	Hollow screw, G 1/4"	1
148	1173.400.044	Hose	1
149			
150			
151			
152	1910.505.062	Set screw, M 5 x 6	1
* 153	1820.040.109	Tension plug	1
154	1820.010.230	Torque spring	1
155	1174.400.074	Strap guide lever	1
156	1820.020.280	Bushing	2
157	1820.010.231	Torque spring	1

Pos.	Part no	Part name	Quantity
158			
159			
160			
161	1940.311.721	Air plug, G 1/4"	1
162	1911.272.127	Locking screw, G 1/4"	1
163			
164	1820.090.068	Oil label	1
165			
166	1820.090.198	Name tag	1
167	1820.090.172	Label "Made in Switzerland"	1
		<b>Variation USA/CAN</b>	
161	1820.100.019	Air connector, 1/4" NPT	1
163	1820.100.017	Transition connection, G 1/4" x 1/4" NPT	1

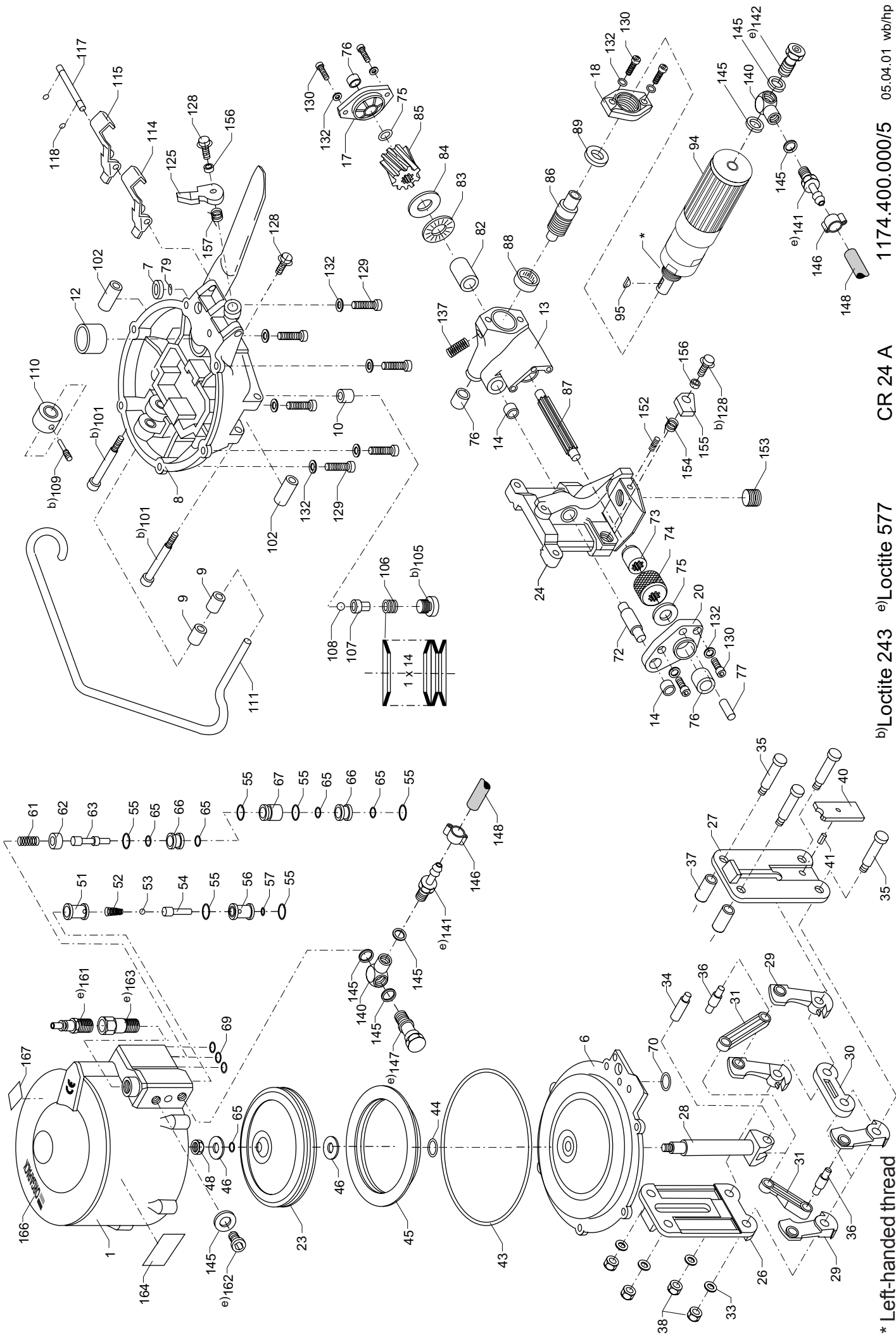

\* Left-handed thread

b) Loctite 243 e) Loctite 577

CR 24 A

1174.400.000/5

05.04.01 wb/hp  
06.03/WE

## 9

## PARTS LIST COMPRESSED AIR MOTOR 1894.422.000/1

When ordering please indicate part number and quantity

Explosion drawing see page 30

Pos.	Part no	Part name	Quantity
1	1894.432.012	End plate	1
2	1894.432.011	Gear housing ( Rear side)	1
3	1894.432.026	Silencer	1
4	1894.432.027	Mesh screen	1
5	1894.432.005	Ball bearing	1
6	1894.432.004	Bearing plate rear	1
7	1894.432.006	Pin	1
8	1894.432.003	Cylinder	1
9	1894.422.001	Rotor	1
10	1894.422.002	Blade	5
11	1894.432.002	Key	1
12	1894.432.009	Bearing plate front	1
13	1894.432.001	Ball bearing	1
14	1894.432.013	Washer	1
15	1894.432.021	Ball bearing	4
16	1894.332.015	Shaft	2
17	1894.332.016	Needle cage	2
18	1894.422.003	Planetary wheel	2
19	1894.422.004	Planetary shaft	1
20	1894.432.025	Threaded bushing	1
21	1894.432.024	Saucer spring	2
22	1894.432.017	Shaft	2
23	1894.332.024	Bearing needle	32
24	1894.432.016	Planetary wheel	2
25	1894.432.018	Planetary shaft	1
26	1894.432.023	Gear housing ( Front side)	1
27	1894.332.027	Gasket	1
28	1894.432.022	Front part	1

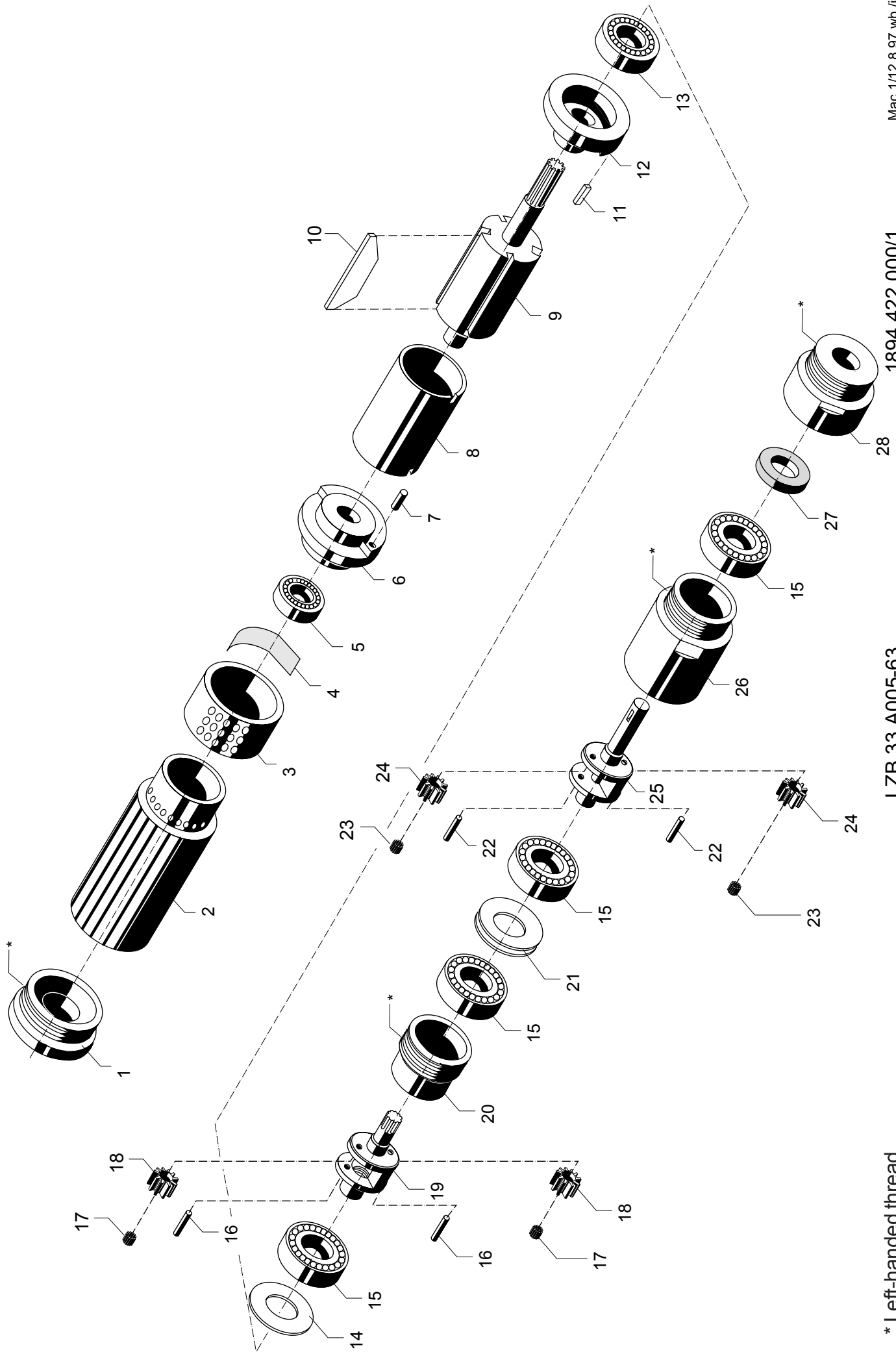

\* Left-handed thread

LZB 33 A005-63

1894.422.000/1

Mac 1/12.8.97 wb /ja