

2-EZ[®] XL / 2-EZ[®] XXL 2-EZ[®] 3XL



Case Erector/Bottom Taper - Large Cases

Combi Packaging System's heavy duty side belt drive case erectors form and bottom seal large and extra large cases at speeds up to 10 cases per minute. These machines are built for optimal durability, reliability and value. Engineered with the industry's strongest frame (lifetime warranty) for the most demanding 3-shift environments, the 2-EZ[®]XL, 2-EZ[®]XXL and 2-EZ[®]3XL can readily integrate into your existing line. Combi's EZ-load walk-in case magazine and 2-minute changeover system are standard features. The redesigned 2-EZ side belt drive units will provide years of dependable service and can form and seal the widest variety of large cases, from single wall to triple wall corrugated.

2-EZ[®]XL Features:

- Up to 10 cases per minute
- EZ Load Walk-In Case Magazine
- Heavy-duty welded steel construction
- 3M Accuglide II+™ 2" Tapehead
- Pneumatic Carriage Assembly
- Dual Belt Drive Case Indexing
- Self-Cleaning Vacuum System
- Safety Back Up Photo Eye with 20' Cord
- Right Hand or Left Hand Execution

2-EZ[®]XXL and 2-EZ[®]3XL Features:

- Up to 6-8 cases per minute
- EZ load Walk in Powered Case Magazine
- Heavy-duty welded steel construction
- 3M Accuglide II+™ 3" Tapehead
- Pneumatic Carriage Assembly
- Heavy duty Dual Belt Drive Case Indexing
- Self-Cleaning Vacuum System
- Safety Back Up Photo Eye with 20' Cord
- Right Hand or Left Hand Execution
- Motorized magazine elevation



2-EZ[®]XL with Powered Case Magazine

2-EZ[®]XL/2-EZ[®]XXL/2-EZ[®]3XL

Designed to Perform:

The flat case blank stands vertically in the easy to load, walk-in case magazine. The case blank is extracted from the magazine with vacuum cups and formed by a retracting squaring arm. The rear minor flap is rotated 90°. The case is then transferred into the dual belt drives where it is transported across the tape head and is bottom sealed with a strip of pressure sensitive tape.

Options:

- Hot Melt Glue closure
- Heavy Duty Locking Casters
- Low Case Supply Alarm
- Low Tape/No Tape Alarm Kit
- 6" Wide Accuglide II+™ Tape Heads
- Spare Parts Kit
- Cluster Lubrication Kit
- Stainless Steel Framework
- NEMA 4 Water Wash Down
- External Filter for Vacuum Pump
- Powered Case Magazine for 2-EZ[®]XL
- Extended Warranty

Electrical Service:

120 volt/1ph/20A



Combi's exclusive hinged case hold down plate allows for easy tapehead removal. Also, Combi's new open design eliminates overhead cross members in doorways, providing easy access for maintenance.

Distributed by:

Model	Case Size Min (LxWxH)	Case Size Max (LxWxH)	Speed: Cases Per Minute*	Overall System Footprint (approx)
2-EZ XL	13" x 10" x 6" (33x25x15cm)	24" x 20" x 18" (61x51x46cm)	up to 10	8'8" x 8'6" (264x259cm)
2-EZ XXL	21" x 15" x 9" (53x38x23cm)	32" x 26" x 30" (81x66x76cm)	up to 8	10'8" x 11'8" (327x356cm)
2-EZ 3XL	26" x 20" x 15" (66x51x38cm)	36" x 30" x 36" (91x76x91cm)	up to 6	approx 11'8" long

*Speeds are case size dependent

2-EZ XL

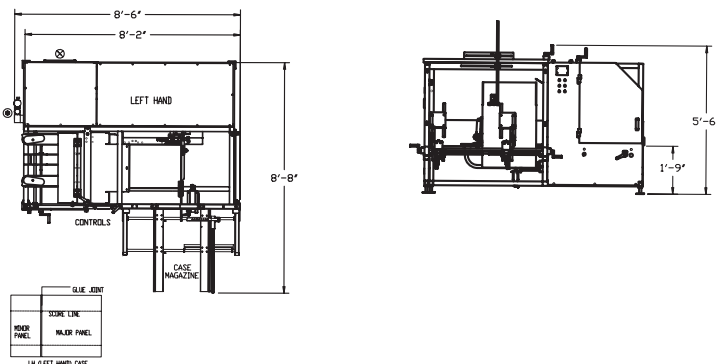

PACKAGING
888-922-1622 WWW.IPACK.COM