



Little David delivers packaging equipment that works for you.

Little David LX-800DT



# LX-800DT Print & Apply

## Functional Labeling for the Real World

This easy to use labeler is designed for dual tamp, single tamp, and corner wrap applications. Enhanced versatility, and simplified operation make the LX-800DT a clear choice for real world print & apply applications.

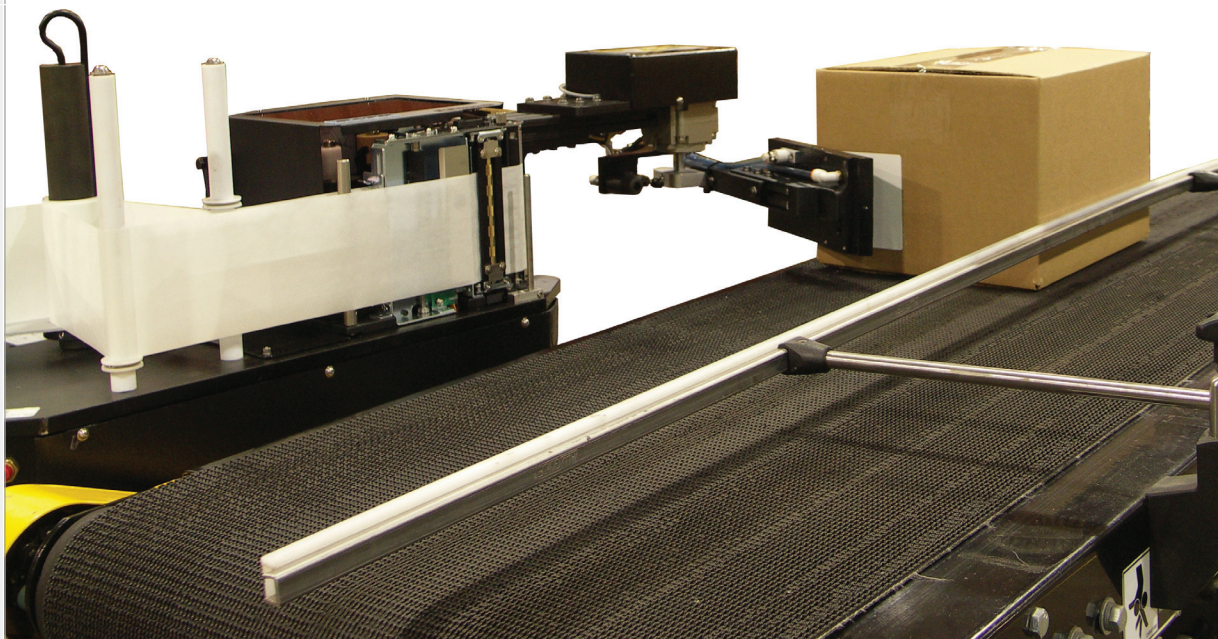

### Features of the LX-800DT Include:

- ☑ Simplified Control Panel with User Friendly Touch Screen
- ☑ Easy-Read Vacuum and Pressure Gauges
- ☑ Isolated Rewind Shut-Off: Allows users to remove used backing material without powering down the unit
- ☑ Simplified Set-Up: From pallet to production in less than 10 minutes
- ☑ Robust Industrial Design
- ☑ UL Listed Controls



LITTLE  DAVID

# LX-800DT

## Features:

- Simplified Control Interface
- Isolated Rewind Shut Off- Disengage rewind for backing removal without powering down the whole system
- Cast Aluminum Frame- Stronger with fewer individual parts
- Increased Width- Frame capable of running max. and min. width of all OEM printers
- Customizable Applicator Pads ( Single/Double/CW Labeling)
- Easily changes from single tamp, to dual tamp, to corner wrap
- Mounting Stand can turn machine to any angle or position

## Machine Specifications:

### Side-Apply

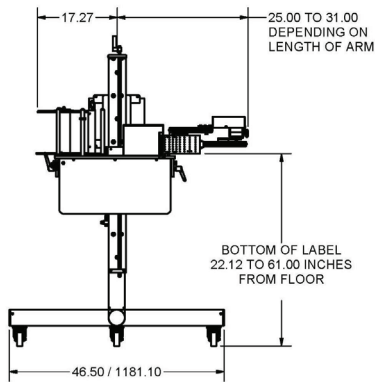

### Top-Apply

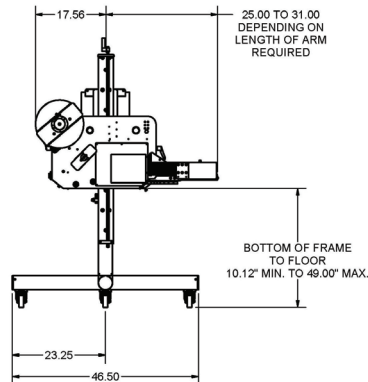

## Printer/Applicator Data:

- Standard Printer:** Sato S84 or SE Series (Zebra Available)
- Printing Label Speed:** Up to 16" per second
- Accuracy:** +/- 1/32" (+/- .79mm) with constant product delivery
- Product Sensing:** Photoelectric (diffused proximity)
- Label Sensing:** Photoelectric(printer)
- Print Resolution:** 203 dpi, 305 dpi, and 609 dpi
- Printing Method:** Thermal transfer printer (direct thermal available)
- Communication Interface:** RS232C (optional interfaces available)
- Bar Code Symbology:** UPC-A, UPC-F, EAN-8, Code 39, Code 128 Interleaved 2/5, UCC/EAN 128, Postnet, 2D and many others.

## Label Specifications:

\*Exact dimensions dependant on printer selected

### Label Dimensions:

 (Sato and Zebra specs. below)

- Width: .75" - 6.6" (19.05mm- 167.64mm)
- Length: 1" to 12"(25.4mm - 304.8mm) - in excess of 12" is available

### Label Roll Requirements:

- Finish: Pressure sensitive die cut with 1/8" (3.17mm) gap
- Outside Diameter: 11-7/8" (301.6mm)
- Core Diameter: 3" (76.2mm)  
Optional 4" (101.6mm) for labels over 6" (152.4 mm) long
- Outside Wound

## Available Options:

- Low label sensor with 3 color light pole
- Incoming Air Dryer
- Cleanable Vacuum Filters
- Hand-held Print Pad
- Spare Parts Kit

## Simplified Touch Screen Interface:

Allows user to upload labels without bringing laptop onto the production floor

- Rugged Design
- Industrial Grade Hardware
- Off the Shelf, Allen Bradley Components

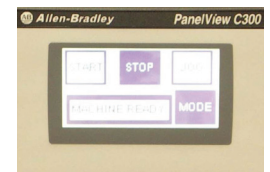

## Included Mounting Stand

- Redesigned stand allows machine to be turned to any angle or position.
- Utilizes total-lock casters



## Distributor Information:



# PACKAGING

888-922-1622

WWW.IPACK.COM



©Loveshaw, an ITW Company, 2010