



PACKAGING

888-922-1622

WWW.IPACK.COM



USC 2020-TB/2''

METRIC

UM197TW

SERIAL # STARTING BY *TM197*

OPERATION MANUAL

&

PARTS LISTS

**This Manual Covers Machines With Serial Numbers Starting With
TM197. For Other Numbers, Contact Customer Service
@ 800-972- 4675**

TABLE OF CONTENTS

TABLE OF CONTENTS.....	1
GENERAL SAFETY RULES.....	2
DIMENSIONAL DRAWING	3
SPECIFICATIONS OF USC 2020-TB	4
LEGEND OF THE MACHINE	5
POWER SOURCE WIRING	6
LEVELING ADJUSTING	7
BOX WIDTH ADJUSTING	8
BOX HEIGHT ADJUSTING	9
DRIVING BELT TENSION ADJUSTING	10
SET-UP PROCEDURES.....	11
SET-UP PROCEDURES.....	12
MAINTENANCE AND LUBRICATION	13
TROUBLE SHOOTING	14-15
PARTS LISTS	16-24

GENERAL SAFETY RULES

- 1. Read and understand the entire instruction manual before operating the machine. Know its limitations, as well as the specific potential hazards peculiar to it.**
- 2. Make certain the machine is properly grounded.**
- 3. Before operating the machine, remove ties, rings, watches, other jewelry, and roll up sleeves above the elbows. Remove all loose clothing and confine long hair. Do not wear gloves.**
- 4. Keep the floor around the machine clean.**
- 5. Keep machine guards in place at all times when the machine is in use.**
- 6. Do not over reach. Maintain a balanced stance at all times so that do not fall or lean against blades or other moving parts.**
- 7. Make all machine adjustments or maintenance with the machine unplugged from the power source.**
- 8. Replace warning labels if they become obscured or removed.**
- 9. Make sure the power source switch is in the OFF position before connecting the machine to the power source.**
- 10. Make a habit of checking to see that the keys and adjusting wrenches are removed before turning on the machine.**
- 11. Keep belt guard and blade guards in place and in working order.**
- 12. Failure to comply with all of these warning could lead to serious injury.**

DIMENSIONAL DRAWING

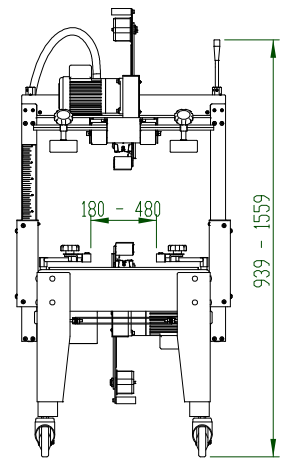
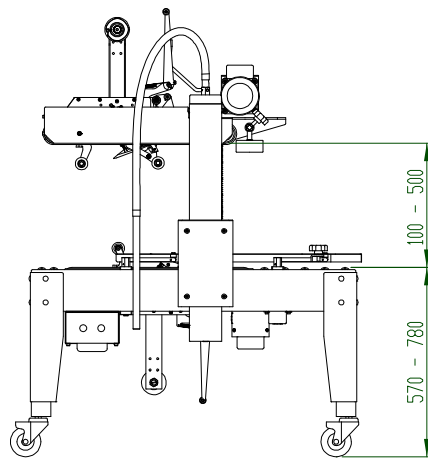
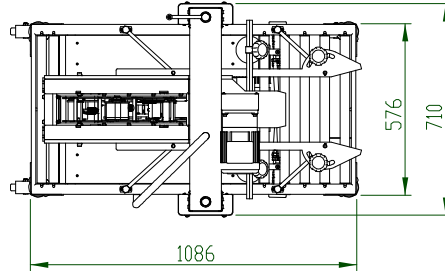

SPECIFICATIONS :

Range of box dimensions	Length 150-unlimited mm Width 180-480 mm Height 100-500 mm
Tape width	3" (75mm)
Driving belt speed	22m/min (60Hz power source) 18m/min (50Hz power source)
Box driving device	Top and bottom driving motor
Height of roller conveyor table	570-780mm (adjustable)
Motor	1/4HP (Upper belt) 1/4HP (Lower belt)
Machine dimensions	1086(L) x 710(W) x 1559(H)mm
Power source	single phase 100/110/220V three phase 220/380V
Net weight	118 kgs
Gross weight	148 kgs

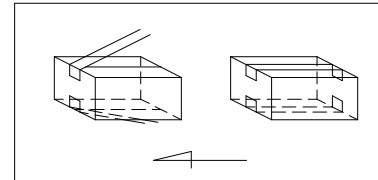
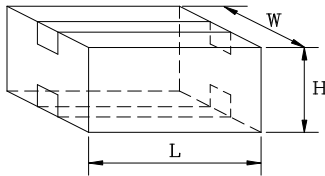

LEGEND OF THE MACHINE

- | | |
|----------------------------------|------------------------------------|
| 1. Leveling and adjustment screw | 8. Upper tape head driving motor |
| 2. Caster | 9. Lower tape head driving motor |
| 3. Control box | 10. Height adjustment crank handle |
| 4. Upper tape head mechanism | 11. Carton guide rail |
| 5. Lower tape head mechanism | 12. Width adjustment knob |
| 6. Upper tape head driving belt | 13. Guide wheel |
| 7. Lower tape head driving belt | 14. Guide wheel adjustment knob |

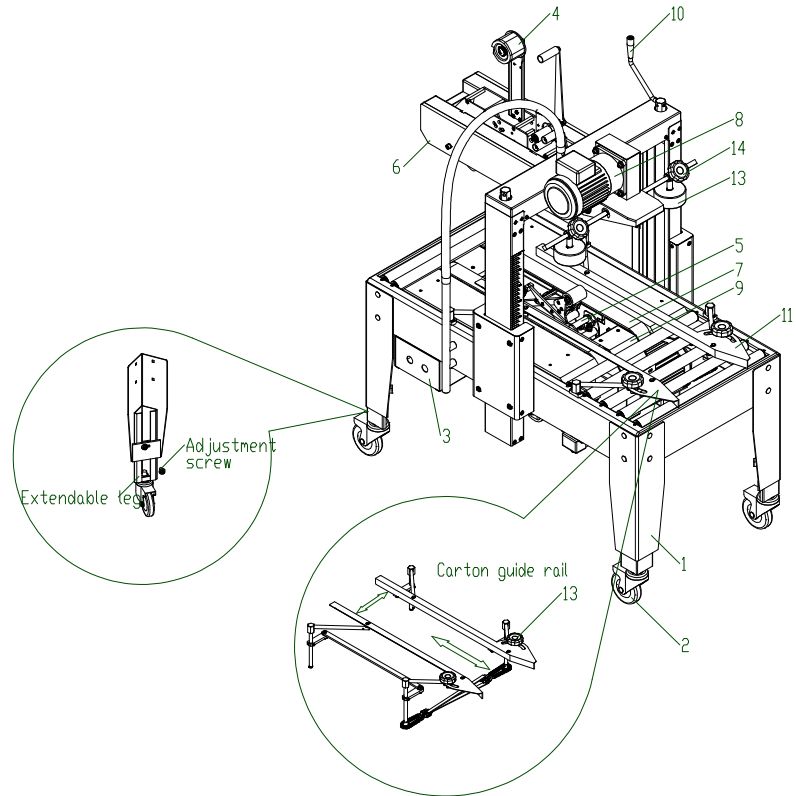

POWER SOURCE WIRING

1. Before connecting, make sure the voltage is the same for both the machine and the power source.

All electrical informational (such as voltage) has been wired before shipment, and is indicated on the electrical instruction label.

2. Connect the power source wires to the "R.S.T." connection points.

The machine must be properly grounded to prevent possible damage from electric shocks. (3 phase only)

3. After the power source wires have been connected, check to see if the wires are connected to the correct points by the running direction of the left and right driving belts. If the driving belts run in the correct direction, then the power source wires are connected to the correct points. If the driving belts run in the opposite direction, cut off the power source and change any two of the three power source wires to obtain the correct running direction. (3 phase only)

LEVELING ADJUSTMENT FOR ROLLER CONVEYOR TABLE

Once the machine has been located at the work site, there needs to be a proper leveling Adjustment for the roller conveyor table to suit your production line.

The leveling adjustment screws are located at the bottom of the 4 legs. Make the leveling Adjustment by simply turning the leveling adjustment screws. Loosen the lock nut before you do it. Tighten-up the lock nut after the level has been properly adjusted.

Fix the machine in place after the leveling adjustment. Press the caster lock pedal for fixing the machine on work site.

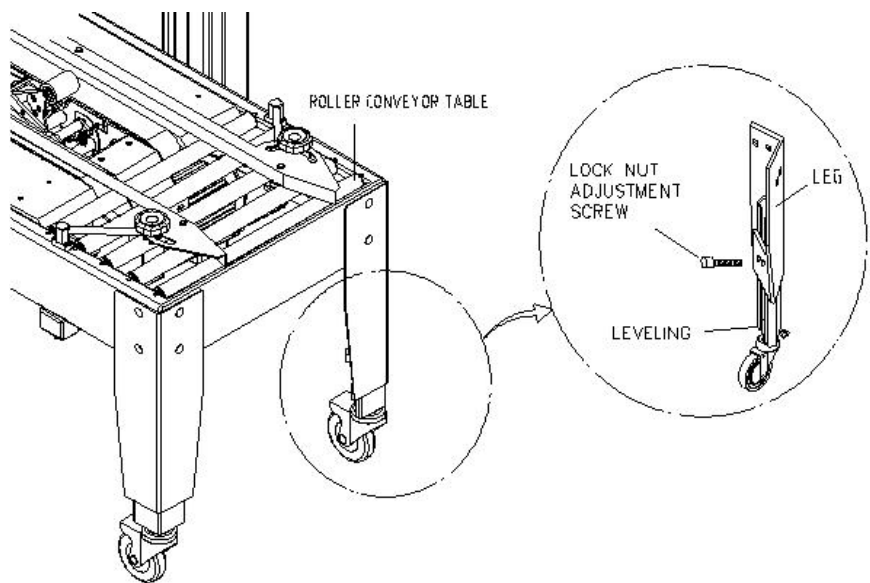

BOX WIDTH ADJUSTMENT

1. Loosen the guide wheel fixing knob.
2. Move the guide wheel directly with your hands until the distance between guide wheels is about 30-50mm wider than the width of the box.
3. Loosen the width adjustment knob, move right/left clamping guide rail outward until the distance between the right and left rails is wider than the width of the box.
4. Place a box onto the roller conveyor table in proper position (see page 4) with the top and bottom covers folded. Move the right and left rails so that they properly press against both sides of the box. Tighten the width adjustment knob.
5. Adjust the box height.
6. Move the guide wheels so that they touch both top sides of the box.
7. Tighten the guide wheel fix knobs.

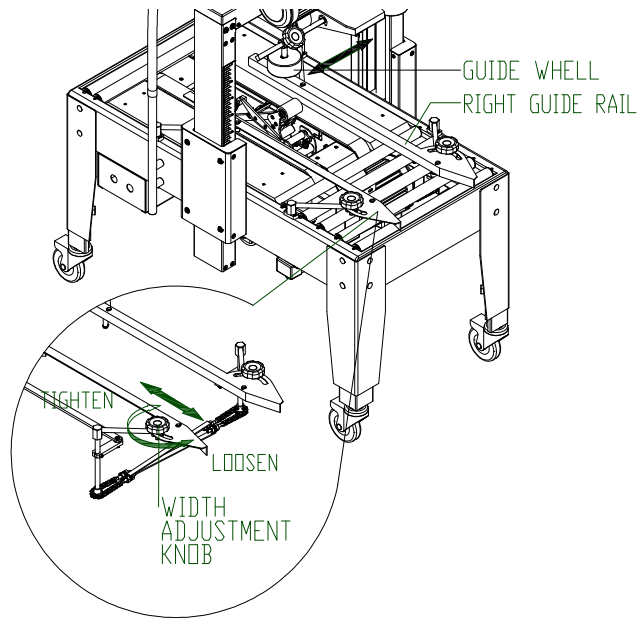

BOX HEIGHT ADJUSTMENT

- 1. Make sure the box height.**
- 2. Turn the height adjustment crank handle until the top driving belt holds down the box.**
- 3. The box height can be read on the height gauge attached to the left frame of the machine.**

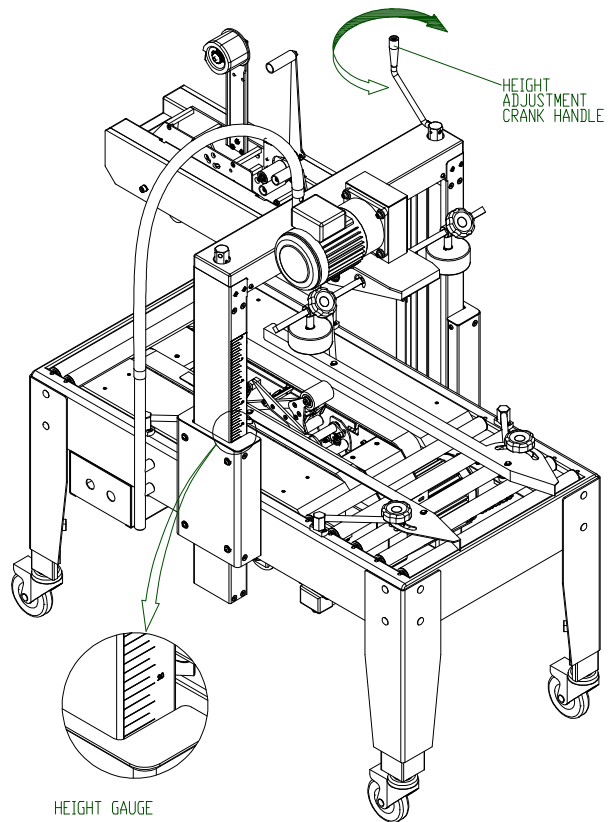

ADJUSTING UPPER AND LOWER DRIVING BELT TENSION

In case the driving belt is too loose to drive the carton, simply adjust the belt tension.

To do this, loosen the belt tension fix nut, and move the screw clockwise to tighten the belt tension until proper tension is obtained, then tighten the belt tension fix nut, (Both sides of the screw should be adjusted simultaneously)

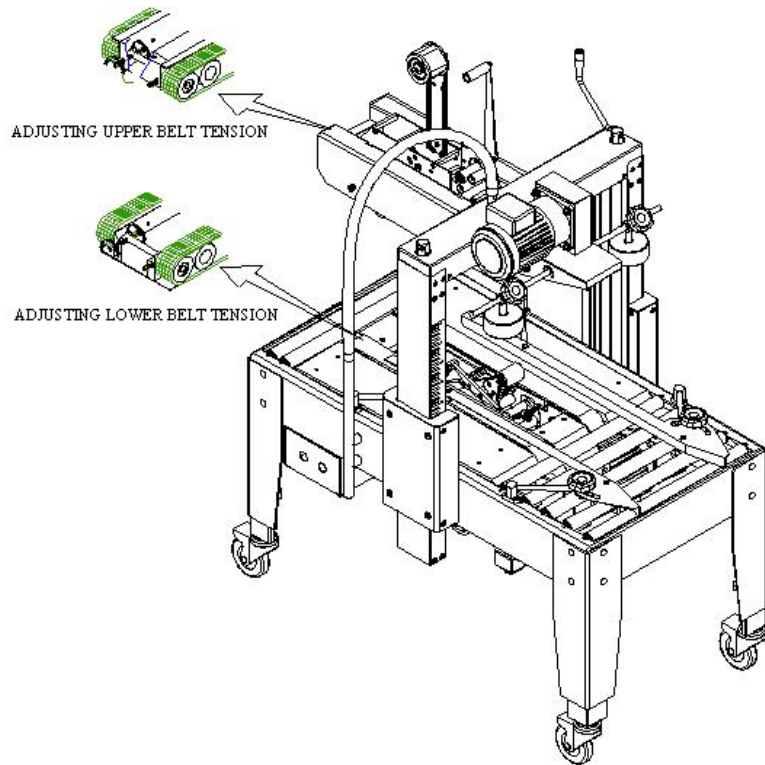

IDENTIFICATION BEFORE OPERATION

1. **Make sure the voltage level is correct.**
2. **Check to see if the driving belts run in the correct direction. (3 phase only)**
3. **Is width and height for box size correctly adjusted?**
4. **Keep all guards in place and in working order.**
5. **Make sure the tape has been properly installed.**

OPERATION PROCEDURES

- 1. Place the box to be sealed onto the roller conveyor table.**
- 2. Adjust the width of right and left driving belt.**
- 3. Adjust the height of top driving belt.**
- 4. Adjust the width of the guide wheel.**
- 5. Start the driving belt to feed the box forward.**
- 6. Check to see if the box feeds smoothly. Make proper adjustment in accordance with Procedures (2) (3) (4) if necessary.**
- 7. Then feed the box into the inlet end of the driving belt. The box will automatically Move through the tape heads for sealing operations on the top and bottom of the box.**

MAINTENANCE AND LUBRICATION

To ensure the service life of the machine, lubricate periodically all moving points as instructed by the arrowhead on the figures below :

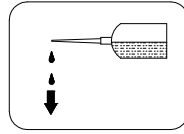

LUBRICATION OF TAPE HEAD MECHANISM
(Refer to Tape Head manual)

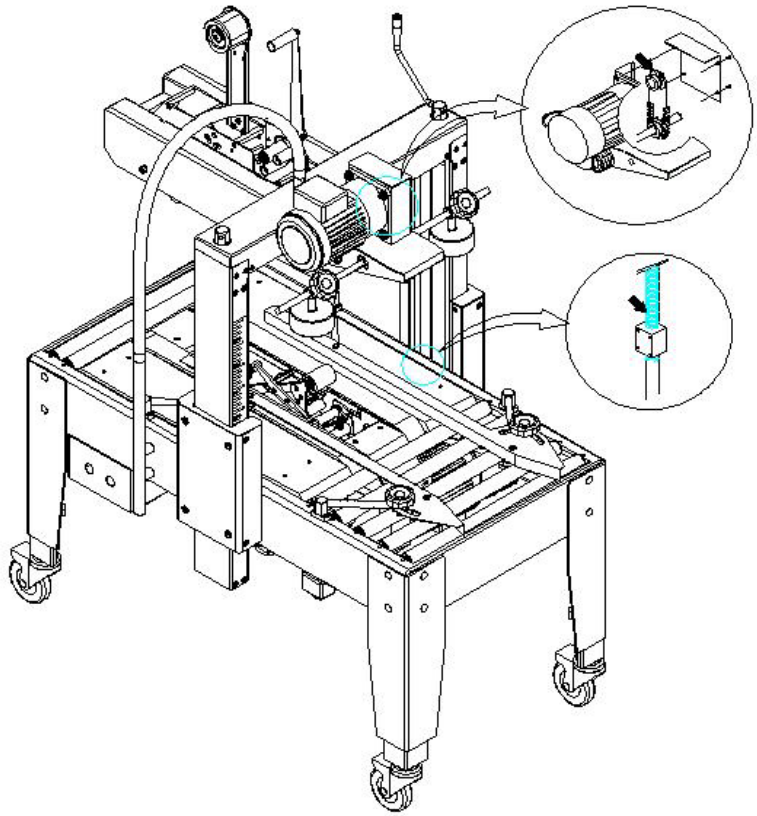

TROUBLE SHOOTING

TROUBLE	PROBABLE CAUSES	REMEDY
Tape isn't being cut-off	<ul style="list-style-type: none"> *Knife is not sharp enough *Knife tip is jammed with adhesive 	<ul style="list-style-type: none"> *Replace with a new knife *Clean the knife with Volatile solvent
A trailing of tape after cut-off motion	<ul style="list-style-type: none"> *Unsmooth motion of knife holder due to choke *Knife holder extension spring fatigue. 	<ul style="list-style-type: none"> *Check if the Knife holder screws are loose. Lubricate when necessary. *Replacement.
Tape is not fully adhering to the box.	<ul style="list-style-type: none"> *Main spring too loose *The roller shafts which tape run over are not effected due to accumulated tape adhesive. *Tape wheel adjustment nut too tight. 	<ul style="list-style-type: none"> *Tighten the main spring *Lubricate those roller shafts *Loosen it.
Box choked on the way	<ul style="list-style-type: none"> *Improper Box Height adjustment. *Main spring too tight. 	<ul style="list-style-type: none"> *Re-adjust the height. *Loosen the main spring.
Tape broken during sealing on box	<ul style="list-style-type: none"> *Knife protrudes too far. 	<ul style="list-style-type: none"> *Lower the knife position
Tape can't travel smoothly	<ul style="list-style-type: none"> *Tape adhesion is not even *The roller shafts which tape runs over are not effected due to accumulated tape adhesive. *Irreversible roller is not affected. *Tape loaded incorrectly *Tape wheel adjustment nut 	<ul style="list-style-type: none"> *Replace with a new tape roll *Lubricate those roller shafts *Replacement. *Correct tape loading so that adhesive side faces upward. *Loosen it.

	too tight.	
Tape mistakes frequently	*Irreversible roller is not affected.	*Replace
* Tape is off central application	*Both Guide wheels give uneven pressure on the box.	*Re-adjust the distance between both Guide wheels.

TROUBLE SHOOTING

PROBLEM	PROBABLE CAUSES	REMEDY
Tape end wrinkling on the carton.	<ul style="list-style-type: none"> * Tape wheel assembly (A) is too tight. * Inside tape wheel assembly with sharp edges & dust. * Tape dose not travel smoothly. * Knife is not sharp enough or is jammed with tape adhesive. * The knife holder is not functioning smoothly * Bronze roller (irreversible roller) is not functioning. 	<ul style="list-style-type: none"> * Loosen tape wheel assembly spring. * Remove tape wheel washer sharp edges and keep it clean. Grease the tape wheel. * Lubricate the roller shafts which the tape runs over. * Clean the knife with alcohol (Volatile solvents). * Check and lubricate to ensure that it functions smoothly. Adjust the knife holder's spring tension. * Replace it.
NOTE : Clean the knife daily with a toothbrush and alcohol.		

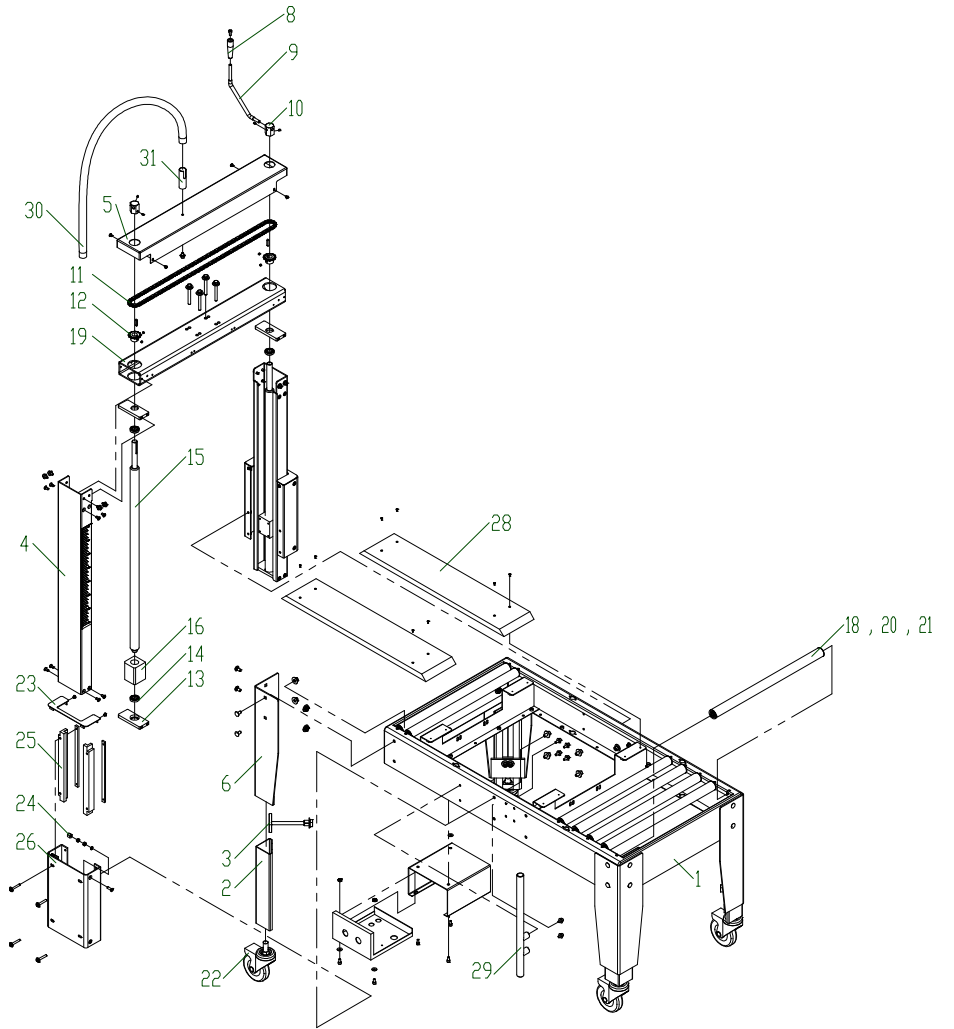

BASE, FRAME AND ELEVATION ASSEMBLY

NO.	ITEM NUMBER	DESCRIPTION	Q'TY
1.	BA73-101A	Base	1
2.	E00-1020	Extension leg	4
3.	E00-1030	Leg fixing piece	4
4.	BA73-103	Frame	2
5.	BA73-108A	Top beam	1
6.	BA73-102	Machine leg	4
7.			
8.	E00-1080	Crank handle knob	1
9.	E00-1090	Crank handle	1
10.	E00-1100	Bush	2
11.	RS-35	Chain	1
12.	RS131217	Chain sprocket	2
13.	BA73-113	Bearing mounting plate	4
14.	6903ZZ	Ball bearing	4
15.	BA73-107	Elevation screw	2
16.	E72-2040	Nut	2
17.		Rule gauge	1
18.	ROL-0494	Roller	6
19.	BA73-106	Top Beam	1
20.	E00-1200	Plastic bush	12
21.	ROS-509	Roller shaft	6
22.	E00-1280	Caster	4
23.	BA73-109	Mast holder	2
24.	E71-PL28A	Block	8
25.	BA73-105	Column Block	4
26.	BA73-104	Outer Column	2
27.			
28.	BA73-116A	2" Table Cover (left, right)	2
29.	E00-1232	Power wire guard pipe	1
30.	E00-1240	Flexible pipe	1
31.	E00-4251	Power wire guard pipe	1
32.			
33.	BA73-110	Block Fix Plate	4
34.	BA73-114	Upper frame (Control Box)	1
35.	BA73-115	Lower frame (Control Box)	1

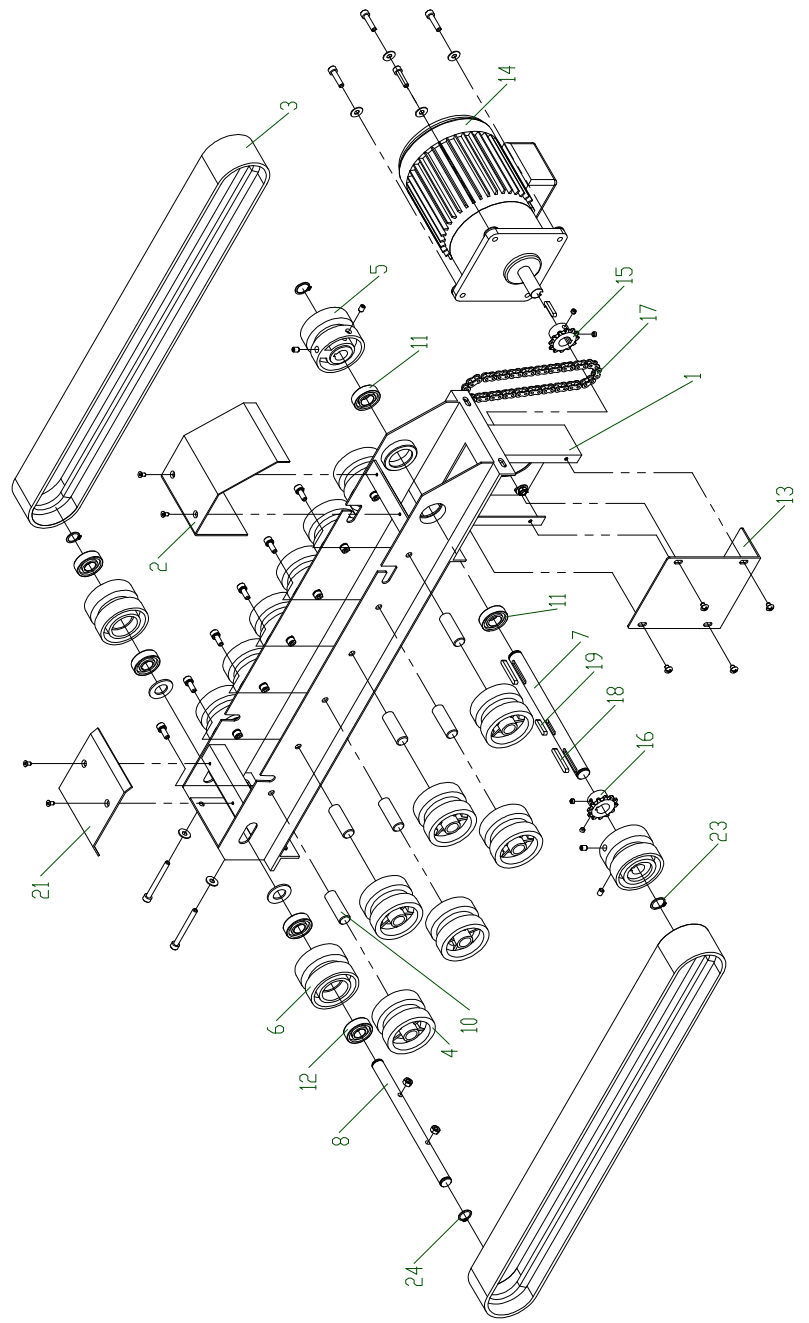

NO.	ITEM NUMBER	DESCRIPTION	Q'TY
1.	73WS2011	Lower tape head frame (2")	1
2.	73WS2021	Lower gear guard (2")	1
3.	E00-4030	Driving belt (50x1334)	2
4.	E00-4040	Plastic pulley	12
5.	73WS4050	Driving aluminum pulley	2
6.	73WS4060	Driven aluminum pulley	2
7.	73WS4160	Driving pulley shaft (2")	1
8.	73WS4170	Driven pulley shaft (2")	1
9.			
10.	E00-4190	Plastic pulley shaft(2)	12
11.	6003ZZ	Ball bearing	2
12.	6202ZZ	Ball bearing	4
13.	E72-4080	Lower chain wheel guard	1
14.	E00-2080	Motor (1/4HP, 1:18)	1
15.	E00-4100	Driving chain sprocket RS#35, 12T, ⚙️16	1
16.	E00-4090	Driven chain sprocket RS#35,12T, ⚙️17	1
17.	RS-35	Chain	1
18.	K540	Round end key	2
19.	K525	Round end key	2
20.			2
21.	CONSULT FACTORY	Rear cover plate, bottom belt base (2")	
22.			
23.	C-S17	"C" circler	2
24.	C-S15	"C" circler	2
25.			

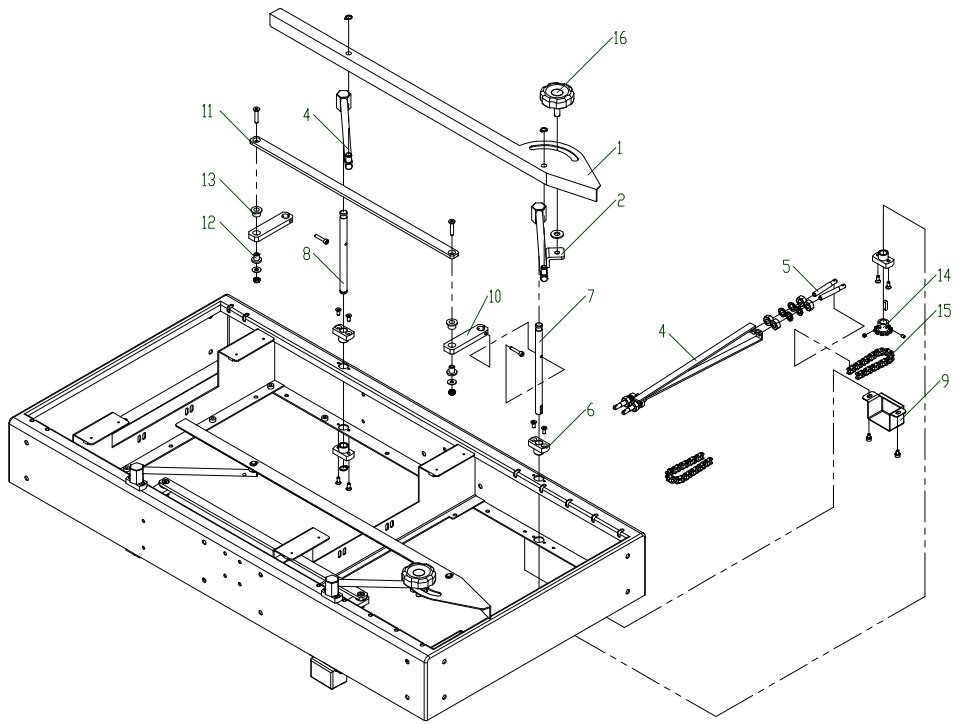

NO.	ITEM NUMBER	DESCRIPTION	Q'TY
1.	E73-3010(B)	Box clamping guide rail(L & R)	2
2.	L70-3030	Guide rail connection rod (front)	2
	E3-044	Connection rod fix piece	1
	L70-3030A	Connection rod	2
	E1-027	Rotary shaft	2
	E1-028	Fix bolt, connection rod	2
	BA73-3040	Guide rail connection rod (rear)	2
3.	L70-3030A	Connection rod	2
	E1-027	Rotary shaft	2
	E1-028	Fix bolt, connection rod	2
4.	L70-3100	Adjustment piece	2
5.	E20-0230	Adjustment screw	4
6.	BA73-311	Collar	8
7.	BA73-312	Connection rod shaft (rear)	2
8.	BA73-313	Connection rod shaft (front)	2
9.	BA73-314A	Guard	2
10.	BA73-315	Connection rod	4
11.	BA73-316	Driving rod	2
12.	BA73-317	Connection rod shaft	4
13.	EZ-030C	Brass bushing	4
14.	RS13100A	Chain sprocket RS#35, 10T, ϕ 12.7	2
15.	RS35	Chain	2
16.	E72-4310	Guide wheel fix knob	2

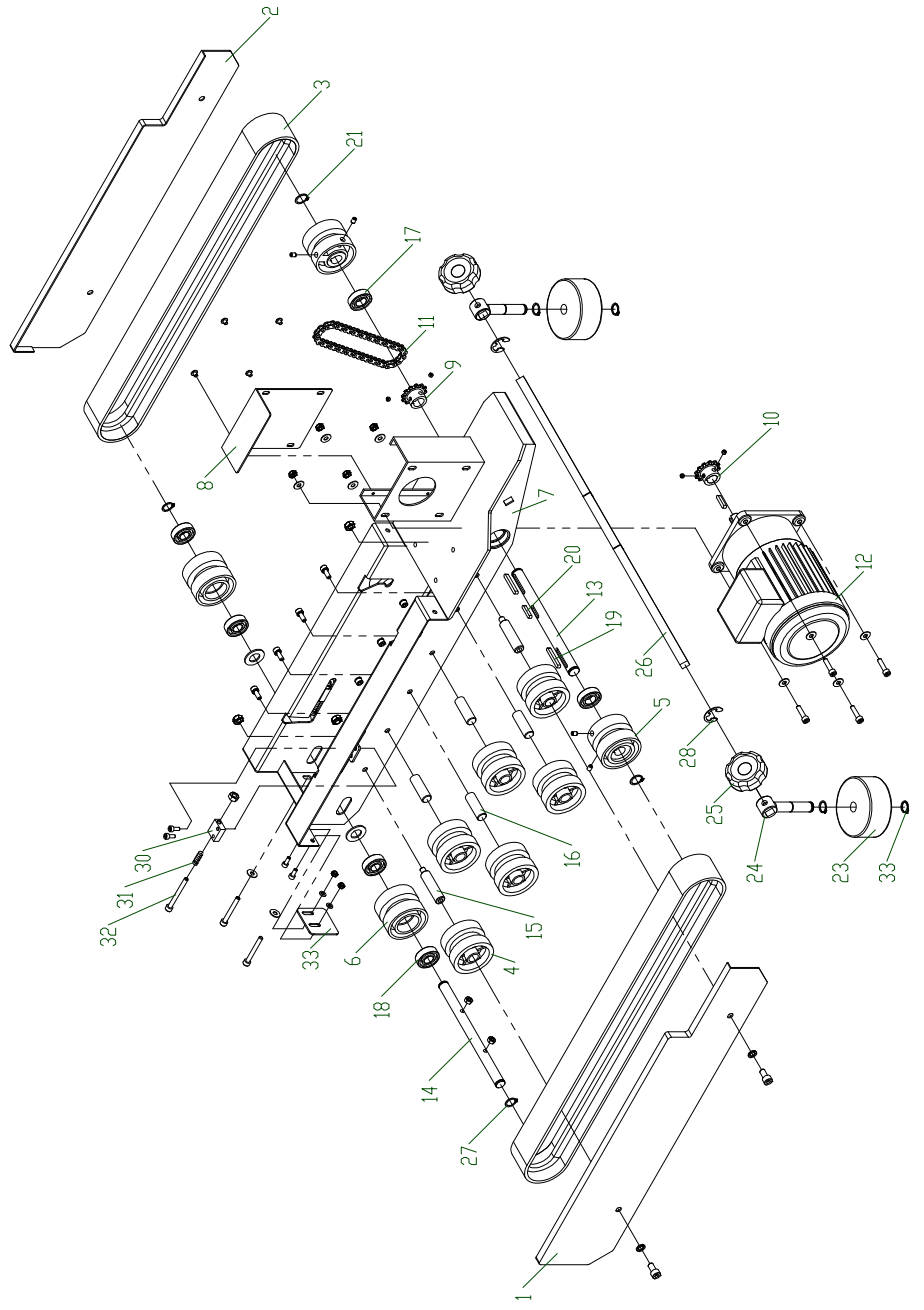

NO.	PART NO.	DESCRIPTION	Q'TY
1.	BA73-405	Upper side guard (right)	1
2.	BA73-405	Upper side guard (left)	1
3.	E00-4030	Driving belt (50x1334mm)	2
4.	E00-4040	Plastic pulley	12
5.	73WS4050	Driving aluminum pulley	2
6.	73WS4060	Driven aluminum pulley	2
7.	BA73-407C	Upper tape head frame	1
8.	E72-4080	Upper chain guard	1
9.	E00-4090	Driven chain sprocket	1
10.	E00-4100	Driving chain sprocket	1
11.	E00-4110	Chain RS#35	1
12.	E00-2080	Motor (1/4HP, 1:18)	1
13.	73WS4160	Driving pulley shaft (2")	1
14.	73WS-4170	Driven pulley shaft (2")	1
15.	E00-4180	Plastic pulley shaft (1)	6
16.	E00-4190	Plastic pulley shaft (2)	6
17.	6003ZZ	Ball bearing	2
18.	6202ZZ	Ball bearing	4
19.	K540	Round end key	2
20.	K525	Round end key	2
21.	C-S17	"C" circlip	2
22.			
23.	E72-4290	Guide wheel	2
24.	E72-4300	Guide wheel arbor	2
25.	E72-4310	Guide wheel fix knob	2
26.	73WS4321	Square shaft	1
27.	C-S15	"C" circlip	4
28.	E-E15	"E" circlip	2
29.	E00-4350	Pointer	1
30.	M4119R0A	Spring holder	2
31.	UPM1068	Tape head spring	2
32.	M4x60L	Hexagonal socket head screw	2
33.	BA73-408	Safety Guard (L & R)	2



PACKAGING

888-922-1622

WWW.IPACK.COM