

# Ergomatic

## Efficient Hand Packing Station

The Ergomatic is a value-priced, semi-automatic hand packing station solution for companies that require more throughput than manual case erecting, packing and sealing can provide. This integrated system provides optimum operator comfort by reducing lifting, reaching, stretching, bending and twisting in the packaging operation. Efficient and durable, the Ergomatic combines a case erector, a custom hand pack station and a Combi semi-automatic, top and bottom sealing case sealer into a cost effective work cell.

### Why Automate Your Hand Packing Line?

- Automatic case erecting and on-demand case presentation w/finger swipe switch reduces reach and wrist movements
- Lifting of products is significantly reduced, resulting in fewer back injuries
- Quick case changeover means minimal machine downtime - ideal for short runs
- Minimizes reach and wrist movement, reducing threat of repetitive motion injuries and medical costs associated with treatment
- Safety interlocked guarding on case erector restricts access to moving parts
- Experience increased profits through increased productivity
- Easy to load, easy to access, walk-in gravity case magazine
- Hand packing assures 100% product inspection
- Mild steel frame components and steel-it paint finish provides a strong yet affordable frame



# Ergomatic

## Common Applications:

- Products that require inspection before packing (meat, dairy, pharmaceutical)
- Short run or variable product sizes going into case
- Products that are difficult to handle automatically
- Packaging operations where full automation is not feasible due to the application or lack of funding

Combi **IS** Custom.  
 Custom **IS** Affordable.  
 Affordable **IS** Common Sense.

## Optional Features:

- Adjustable Speed Conveyor
- External Filter and Gauge for Vacuum Generator
- Vacuum Pump with External Filter and Gauge
- Mobility Package
- 3" Tapehead
- Low Tape/No Tape Alarm Kit
- Low Case Supply Alarm

Distributed by:

Model	Case Size Min (LxWxH)	Case Size Max (LxWxH)	Speed: Cases per Minute	Overall System Footprint Two Person Station
E2500 Ergomatic	8½ x 4¾ x 4" (216x121x102mm)	20 x 13½ x 19½" (508x343x495mm)	10	15'10¼" x 7'4" x 5'4½" (483x224x163cm)
E3000 Ergomatic	13 x 7¾ x 6" (330x197x152mm)	24 x 16 x 16" (610x406x406)	10	16'7"x8'11"x5'9" (505x272x175cm)

E2500 Ergomatic

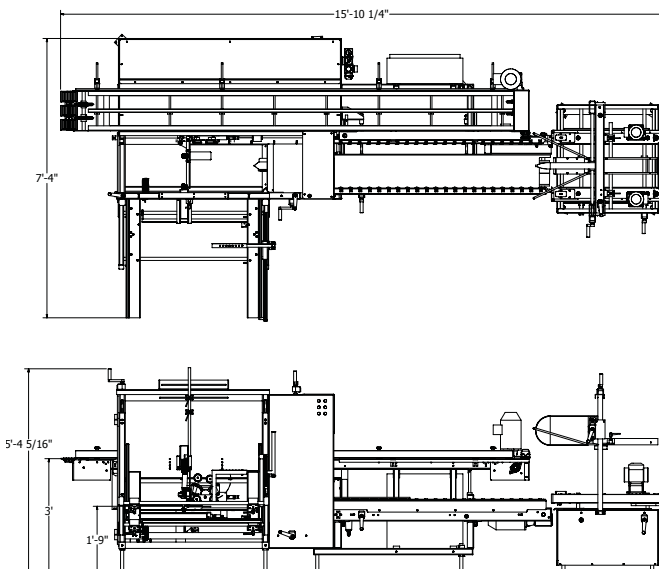

**IDS**  
**PACKAGING**  
 888-922-1622 WWW.IPACK.COM