

2-EZ[®] SB/HS Ergopack[®]



High Speed Handpack Stations

The productivity of the innovative Combi Ergopack[®] has been raised with the addition of our side-belt driven, high speed case erectors. Now an even larger variety of product sizes, shapes, weights and materials can be quickly and easily packed in a larger range of case sizes at speeds up to 20 cases per minute. These ergonomically designed systems feature a hands-free indexing system that positions cases and product for optimal operator comfort, minimizing repetitive wrist and arm motions. Variable speed product infeed and on-demand case presentation combined with your choice of up to five operator pack stations provide ultimate flexibility. These systems feature the built-in strength, ease of maintenance and customer support you can expect from all Combi equipment.

High Speed Ergopack Features:

- Ergonomically designed hands free case indexing system reduces reach and wrist movements
- Lifting of products is significantly reduced, resulting in fewer back injuries and discomfort
- Reduces costly physical stressors associated with manual case erecting, hand packing and sealing
- Ideal for short runs - quick case changeovers
- Increases profits through increased productivity
- A compact and cost effective workcell results from combining a high speed case erector, a handpack station and a case sealer
- Available in stainless steel, washdown components for the food and chemical industries
- Thoroughly customized design to meet your application and product requirements



*2-EZ[®]SB Ergopack
optional Stainless Steel frame*

Sequence of Events:

The case blank is extracted from the magazine with vacuum cups and formed by a retracting squaring arm. The rear minor flap is rotated 90°. The case is then transferred into the dual belt drives where it is transported across the tape head.

The bottom sealed case is then discharged on to the Ergopack case conveyor and presented to the operators. The operators drag, guide and drop product from the product conveyor into the waiting case.

Once the case is filled, the operator swipes the finger switch to advance the case into the case sealer where the top flaps are closed and the case is sealed by pressure sensitive tape. As a filled case advances to the case sealer, a new case is presented to the operator from the case erector.

Optional methods of case closure include hot melt glue and staples.

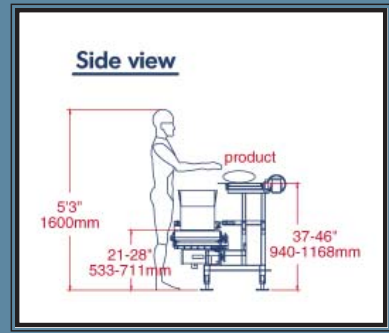

Combi Packaging Systems is the first equipment manufacturer to provide an ergonomic solution for hand packing. Ideal for food packing applications requiring inspection before packing; packing products of variable sizes where total automation is impractical; irregular shaped items that don't lend themselves to automation; or applications where you need more than a stand-alone case erector but less than total automation.

To read an engineering study on the ergonomic advantages of this machine, go to <http://www.combi.com/uploads/126401311252688.doc>

Model	Case Size Min* (L x W x H)	Case Size Max (L x W x H)	Speed: Cases per Min**	Overall System Footprint
2-EZ SB Ergopack	8" x 6" x 5" (203x152x127mm)	20" x 16" x 16" (508x406x406mm)	up to 15	20'5" x 8'4" (622x254cm)
2-EZ Plus SB Ergopack	8" x 6" x 5" (203x152x127mm)	24" x 16" x 16" (610x406x406mm)	up to 12	20'5" x 8'4" (622x254cm)
2-EZ HS Ergopack	8" x 6" x 5" (203x152x127mm)	24" x 16" x 18" (610x406x457mm)	up to 20	22'5½" x 9'4" (685x284cm)

* Min Case Size for Hot Melt Units 8" x 8" x 5"
 ** Case Size and Operator Dependent

Distributed by:

2-EZ SB Ergopack

