

3M-Matic™ Case Former 700cf



Step up
to a more
productive
work flow

Form, pack and seal up to 15 cases per minute

Still forming and sealing your boxes by hand? The 3M-Matic™ Case Former 700cf can help you boost assembly line speed and productivity—it's up to 25% faster than manual packing methods.

This affordable case sealing system eliminates the awkward, bottom flap-folding step in manual case packing and provides a convenient product packing station. Now your operators can focus on packing boxes quickly and efficiently, improving assembly line throughput.

- Four belts provide positive traction and heavy-duty reliability, shift after shift, for cases up to 85 lbs.
- 3M™ AccuGlide™ 2+ Taping Head ensures consistency and safe, low-impact sealing
- Convenient call switch and emergency stop button improve operator efficiency
- Integrated case size adjustments make changeovers easy
- Compact design is complete with exit conveyor

Box capacities

Length: 6" – 24"
(152mm – 610mm)

Width: 6" – 19"
(152mm – 483mm)

Height: 4.5" – 18.5"
(114mm – 470mm)

Weight: 5 lbs – 85 lbs
(3 kg – 38 kg)

Specifications

3M-Matic™ Case Former 700cf

700cf Footprint

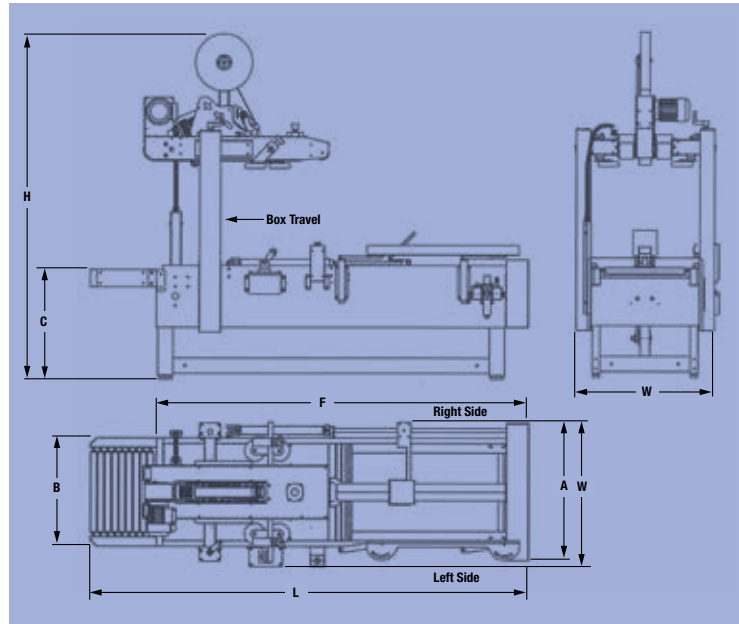

Machine	Tape Size Inches (mm)	Machine Weight* Lbs. (kg)	Machine Dimensions Inches (mm)							Electrical	Operating Rate at 70 psig 3.75 scfm	Drive Belt Speed
			W	L	H	A	B	C	F			
			Width	Length	Height min max	Width at former	Width at exit conveyor	Conveyor Height** min max	Length w/o exit conveyor			
700cf	1.5 - 2 (36 - 48)	496 (225)	29.75 (756)	90.25 (2302)	59.5 (1510) 72 (1810)	28.375 (720)	22.5 (570)	22.625 (575) 28.5 (675)	76.875 (1952)	110V 60 Hz 3.6A 440 watts 8' cord	Up to 15 cases per minute depending on operator and box size	70 fpm (0.22m/s)

*Uncrated

**Without casters. Casters add 6 inches.

Machine	Box Capacities Inches (mm)				Weight Range Lbs. (kg)
	Length Min - Max	Width Min - Max	Height Min - Max	Height Range w/ Masts Raised	
700cf	6 - 24 (152 - 610)	6 - 19 (152 - 483)	4.5 - 18.5 (114 - 470)	—	5 - 85 (3 - 38)

Note: The 3M-Matic™ Case Former 700cf can accommodate most boxes within the size range shown here.

However, if:

Box length in direction of seal
Box height

is less than .75, boxes should be test run to ensure proper system performance.



Product Use: User is responsible for determining whether the product is fit for a particular purpose and suitable for user's method of application.

Warranty and Limited Remedy: THE FOLLOWING WARRANTIES ARE MADE IN LIEU OF ALL OTHER WARRANTIES, EXPRESS OR IMPLIED, INCLUDING, BUT NOT LIMITED TO THE IMPLIED WARRANTY OF MERCHANTABILITY, THE IMPLIED WARRANTY OF FITNESS FOR A PARTICULAR PURPOSE AND ANY IMPLIED WARRANTY ARISING OUT OF A COURSE OF DEALING, A CUSTOM OR USAGE OF TRADE: 3M sells its 3M-Matic™ Case Former 700cf with the following warranties: 1) The Taping Head knife blades, springs and rollers will be free from all defects for ninety (90) days after delivery. 2) All other Taping Head parts will be free from all defects for three (3) years after delivery. 3) All other parts will be free from all defects for two (2) years after delivery. Please refer to individual data pages for additional details and exceptions. If any 3M-warranted part is proved to be defective within its warranty period, then the exclusive remedy and 3M's and seller's sole obligation shall be, at 3M's option, to repair or replace the part, provided the defective part is returned immediately to 3M's factory or an authorized service station designated by 3M. A part will be presumed to have become defective after its warranty period unless the part is received or 3M is notified of the problem no later than five (5) calendar days after the warranty period. If 3M is unable to repair or replace the part within a reasonable time, then 3M, at its option, will replace the equipment or refund the purchase price. 3M shall have no obligation to provide or pay for the labor required to install the repaired or replacement part. 3M shall have no obligation to repair or replace (1) those parts failing due to operator misuse, carelessness, or due to any accidental cause other than equipment failure, or (2) parts failing due to non-lubrication, inadequate cleaning, improper operating environment, improper utilities or operator error. **Limitation of Liability:** 3M and seller shall not be liable for direct, indirect, special, incidental or consequential damages based upon breach of warranty, breach of contract, negligence, strict liability or any other legal theory. The foregoing Warranty and Limited Remedy and Limitation of Liability may be changed only by a written agreement signed by authorized officers of 3M and seller.