

3M-Matic™ Top and Bottom Drive Belt Adjustable King Size Case Sealer 700aks



3M™ AccuGlide™ 3 Taping Head for low impact sealing and higher productivity

4-belt drive for
large boxes
long runs

Shown with optional accessories

Up to 40 cases per minute

For large RSCs used in the appliance, furniture, and other industries, 3M-Matic™ Top and Bottom Drive Belt Adjustable King Size Case Sealer 700aks accurately seals top and bottom flaps at up to 40 uniformly-sized cases per minute. Two belts on top and bottom help assure traction for cases up to 85 pounds (38 kg).

Features include:

- Dual masts with twin lead screws for taping head stability
- Gear motor drive for high volume, heavy duty dependability
- Easy height and width adjustments for a wide range of RSCs
- Designed for use with 48-72mm (2"-3") Scotch® Box Sealing Tapes

- Easily adjusted side guides center cases of various widths for the full length of the unit
- Top flap compression rollers to close flaps for an improved seal
- Centrally-located emergency stop for quick and easy access

Options: Locking casters, low tape indicator, infeed and exit conveyors, and box hold down attachment

Box capacities

Length: 6" to unlimited
(152mm to unlimited)

Width: 7" to 25.5"
(178mm to 648mm)

Height: 4" to 36"
(102mm to 914mm)
See chart on back for selecting height ranges

Weight: 5-85 lbs.
(3-38 kg)

Specifications

3M-Matic™ Top and Bottom Drive Belt Adjustable King Size Case Sealer 700aks



700aks Footprint

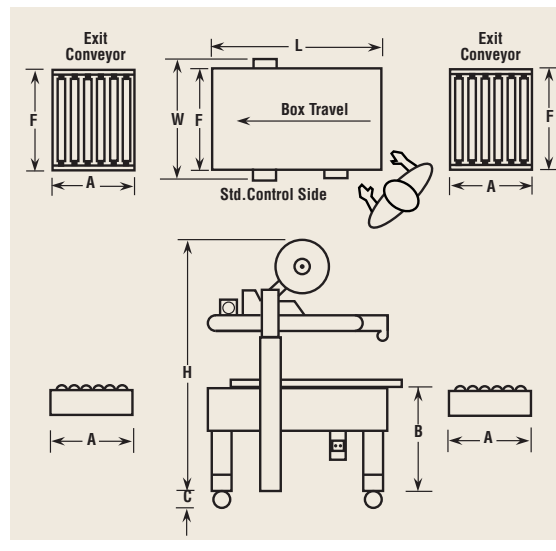

Machine	Tape Size Inches (mm)	Machine Weight* Lbs. (kg)	Machine Dimensions Inches (mm)							Electrical	Operating Rate	Drive Belt Speed
			W	L	H	A	B	C**	F			
					Min.		Min.					
700aks	2-3 (48-72)	375 (170)	33.75 (857)	42.5 (1080)	49.5 (1257) 91.5 (2324)	17 (432)	20.5 (521) 31 (787)	4.75 (121)	29 (737)	115V 60Hz, 5.8A, 675 watts 8' power cord	Up to 40 per minute	100 fpm (0.5 m/s)

*Uncrated **Optional casters T= 60.25 (1530) Use with clean dry boxes in dry, relatively clean environments at 40°F to 120°F (4.4°C to 48.9°C).

Height Ranges:				
Crossbar Position	Mast Position			
	Standard		High	
	Min.*	Max.	Min.	Max.
High	10.75" (273mm)	31.5" (800mm)	15.25" (387mm)	36" (914mm)
Standard	4.75" (121mm)**	25.5" (648mm)	9.25" (235mm)	30" (762mm)
Low	4" (102mm)**	23.5" (597mm)	6.75" (171mm)	27.5" (699mm)

*Can be reduced by an additional .75" (20mm) by removing column stops. For heights below 4.25" (110mm) taping heads must be adjusted to apply 2.00" (50mm) tape leg lengths. ** Use of top flap compression rollers is limited to box heights higher than 5.5" (140mm).

Machine	Box Capacities Inches (mm)			Weight Range Lbs. (kg)
	Length	Width	Height	
	Min. Max.	Min. Max.	Min. Max.	
700aks	6" to unlimited (152mm to unlimited)	7" to 25.5" (178mm to 648mm)	4" to 36" (102mm to 914mm)	5-85 lbs. (3-38 kg)

Contact your 3M representative for special modifications that may be available for sizes not listed.

Note: The 3M-Matic™ Top and Bottom Drive Belt Adjustable King Size Case Sealer 700aks can accommodate most boxes within the size range listed here. However, if:
 Box Length in Direction of Seal
 Box Height
 is less than .75
 Boxes should be test run to ensure proper machine performance.

Note: This technical information and data should be considered representative or typical only and should not be used for specification purposes.

Product Use: User is responsible for determining whether the product is fit for a particular purpose and suitable for user's method of application.

Warranty and Limited Remedy: THE FOLLOWING WARRANTIES ARE MADE IN LIEU OF ALL OTHER WARRANTIES, EXPRESS OR IMPLIED, INCLUDING, BUT NOT LIMITED TO THE IMPLIED WARRANTY OF MERCHANTABILITY, THE IMPLIED WARRANTY OF FITNESS FOR A PARTICULAR PURPOSE AND ANY IMPLIED WARRANTY ARISING OUT OF A COURSE OF DEALING, A CUSTOM OR USAGE OF TRADE: 3M sells its 3M-Matic™ Case Sealer 700aks with the following warranties: 1) The Taping Head knife blades, springs and rollers will be free from all defects for ninety (90) days after delivery. 2) All other Taping Head parts will be free from all defects for three (3) years after delivery. 3) All other parts will be free from all defects for two (2) years after delivery. Please refer to individual data pages for additional details and exceptions. If any 3M-warranted part is proved to be defective within its warranty period, then the exclusive remedy and 3M's and seller's sole obligation shall be, at 3M's option, to repair or replace the part, provided the defective part is returned immediately to 3M's factory or an authorized service station designated by 3M. A part will be presumed to have become defective after its warranty period unless the part is received or 3M is notified of the problem no later than five (5) calendar days after the warranty period. If 3M is unable to repair or replace the part within a reasonable time, then 3M, at its option, will replace the equipment or refund the purchase price. 3M shall have no obligation to provide or pay for the labor required to install the repaired or replacement part. 3M shall have no obligation to repair or replace (1) those parts failing due to operator misuse, carelessness, or due to any accidental cause other than equipment failure, or (2) parts failing due to non-lubrication, inadequate cleaning, improper operating environment, improper utilities or operator error. **Limitation of Liability:** 3M and seller shall not be liable for direct, indirect, special, incidental or consequential damages based upon breach of warranty, breach of contract, negligence, strict liability or any other legal theory. The foregoing Warranty and Limited Remedy and Limitation of Liability may be changed only by a written agreement signed by authorized officers of 3M and seller.