

3M-Matic™ Side Belt Adjustable Case Sealer 800asb

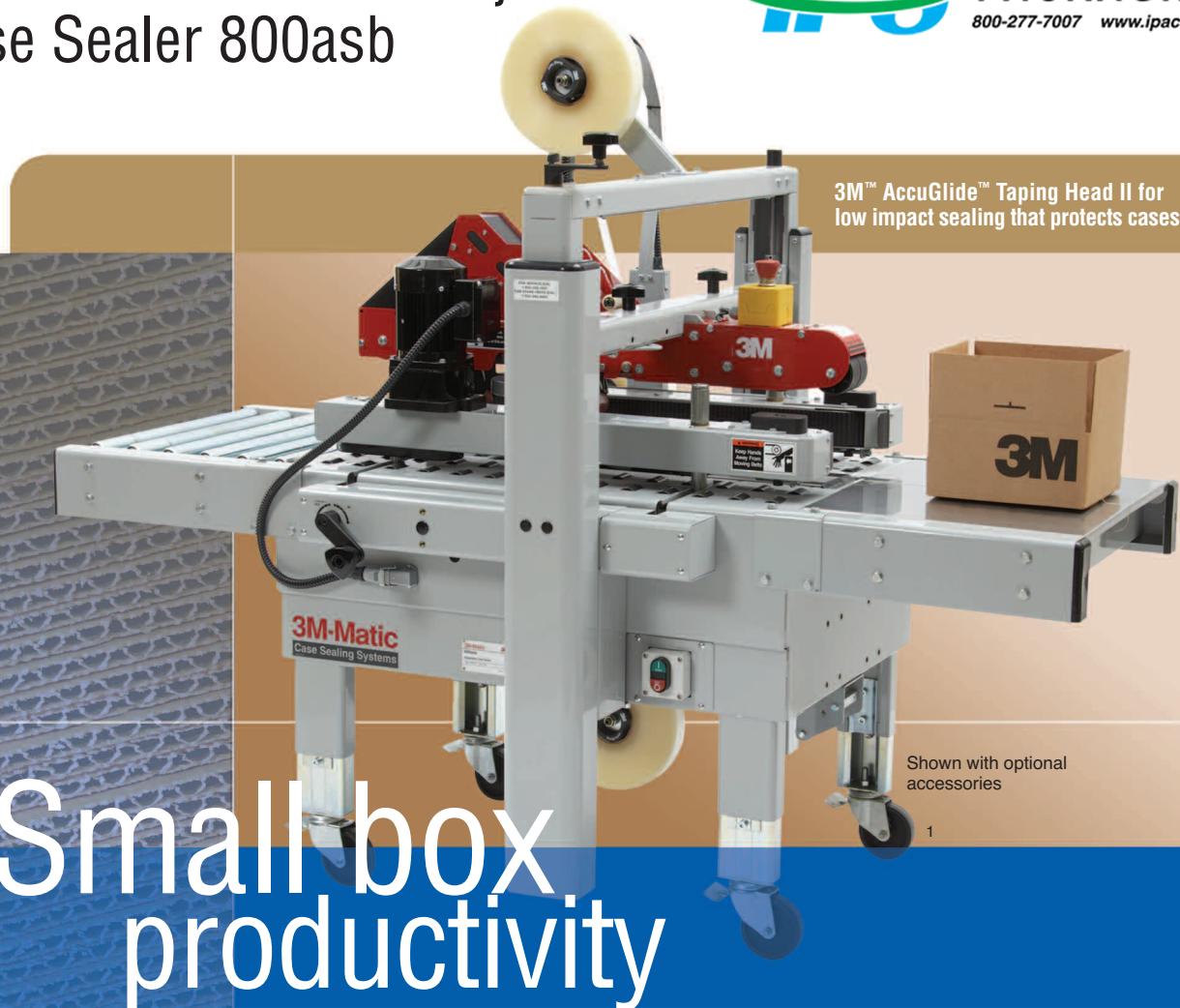

3M™ AccuGlide™ Taping Head II for low impact sealing that protects cases

Shown with optional accessories

Small box productivity

Up to 24 low and narrow cases per minute

Located on each side of the 3M-Matic™ Side Belt Adjustable Case Sealer 800asb traction-grip drive belts center and stabilize low and narrow boxes for consistently accurate taping. Designed specifically to handle small boxes to regain productivity in your operation.

Features include:

- Dual masts with twin lead screws for taping head stability and uniform height adjustment
- Twin gear motor drives for shift after shift dependability with cases up to 85 pounds (38 kg)
- Convenient height and width adjustments for a range of RSCs
- Centrally-located emergency stop for quick and easy access
- Designed for use with 36mm (1.5") Scotch® Box Sealing Tape

Options: Lockable casters for easy movement, infeed platform attachment, exit conveyor, box hold down attachment

Box capacities

- Length: 6" to unlimited (152mm to unlimited)
- Width: 3.9" to 21.5" (99mm to 546mm)
- Height: 2.75" to 22.38"* (70mm to 568mm)
- Weight: 5-85 lbs. (3-38 kg)

* Adjustable to maximum 26.38" (670mm) increasing minimum case height to 4.25" (108mm).

Specifications

3M-Matic™ Side Belt Adjustable Case Sealer 800asb



800asb Footprint

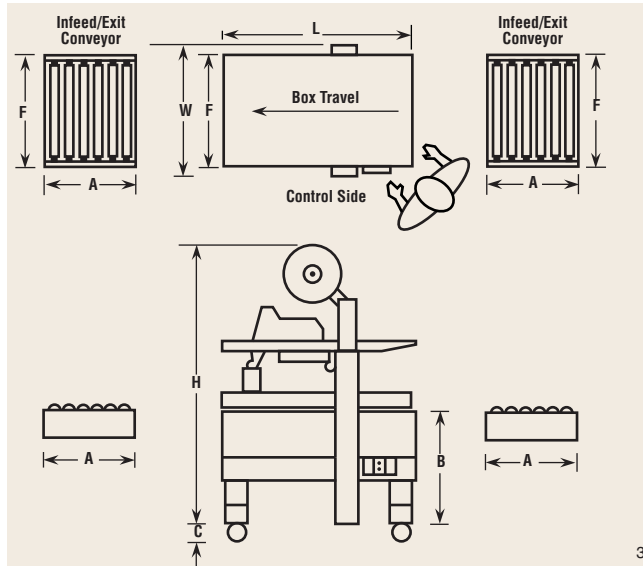

Machine	Tape Size Inches (mm)	Machine Weight* Lbs. (kg)	Machine Dimensions Inches (mm)							Electrical	Operating Rate	Drive Belt Speed
			W	L	H	A**	B	C***	F			
					Min. Max.		Min. Max.					
800asb	1.5 (36)	335 (152)	38.5 (978)	36 (914)	53 (1346) 86 (2184)	18 (457)	24 (610) 35 (889)	4 (102)	24.5 (622)	115V 60Hz 3.8A 440 watts 8' cord	Up to 24 per minute	57 fpm (.3 m/s)

* Unrated ** Optional infeed/exit conveyors *** Optional casters
Use with clean dry boxes in dry, relatively clean environments at 40°F to 120°F (4.4°C to 48.9°C).

Machine	Box Capacities Inches (mm)			Weight Range Lbs. (kg)
	Length Min. Max.	Width Min. Max.	Height Min. Max.	
800asb	6" to unlimited (152mm to unlimited)	3.9" to 21.5" (99mm to 546mm)	2.75" to 22.38" (70mm to 568mm)	5-85 lbs. (3-38 kg)

Contact your 3M representative for special modifications that may be available for sizes not listed.
Note: This technical information and data should be considered representative or typical only and should not be used for specification purposes.

Note: The 3M-Matic™ Side Belt Adjustable Case Sealer 800asb can accommodate most boxes within the size range listed here. However, if:
Box Length in Direction of Seal
Box Height
is less than .75

Boxes should be test run to ensure proper machine performance.



Product Use: User is responsible for determining whether the product is fit for a particular purpose and suitable for user's method of application.

Warranty and Limited Remedy: THE FOLLOWING WARRANTIES ARE MADE IN LIEU OF ALL OTHER WARRANTIES, EXPRESS OR IMPLIED, INCLUDING, BUT NOT LIMITED TO THE IMPLIED WARRANTY OF MERCHANTABILITY, THE IMPLIED WARRANTY OF FITNESS FOR A PARTICULAR PURPOSE AND ANY IMPLIED WARRANTY ARISING OUT OF A COURSE OF DEALING, A CUSTOM OR USAGE OF TRADE: 3M sells its 3M-Matic™ Case Sealer 800asb with the following warranties: 1) The Taping Head knife blades, springs and rollers will be free from all defects for ninety (90) days after delivery. 2) All other Taping Head parts will be free from all defects for three (3) years after delivery. 3) All other parts will be free from all defects for two (2) years after delivery. Please refer to individual data pages for additional details and exceptions. If any 3M-warranted part is proved to be defective within its warranty period, then the exclusive remedy and 3M's and seller's sole obligation shall be, at 3M's option, to repair or replace the part, provided the defective part is returned immediately to 3M's factory or an authorized service station designated by 3M. A part will be presumed to have become defective after its warranty period unless the part is received or 3M is notified of the problem no later than five (5) calendar days after the warranty period. If 3M is unable to repair or replace the part within a reasonable time, then 3M, at its option, will replace the equipment or refund the purchase price. 3M shall have no obligation to provide or pay for the labor required to install the repaired or replacement part. 3M shall have no obligation to repair or replace (1) those parts failing due to operator misuse, carelessness, or due to any accidental cause other than equipment failure, or (2) parts failing due to non-lubrication, inadequate cleaning, improper operating environment, improper utilities or operator error. **Limitation of Liability:** 3M and seller shall not be liable for direct, indirect, special, incidental or consequential damages based upon breach of warranty, breach of contract, negligence, strict liability or any other legal theory. The foregoing Warranty and Limited Remedy and Limitation of Liability may be changed only by a written agreement signed by authorized officers of 3M and seller.