



ARPAC STRETCH™ ELECTRO-WRAP EWA-SERIES®

FLOOR MOUNTED AUTOMATIC ROTARY TOWER STRETCH WRAPPER

The EWA-SERIES® automatic rotary tower stretch wrapper offers portable automation! The system is 100% electric and operates without compressed air, reducing total energy costs and contributing to your green efforts. The machine combines automation and floor space optimization making it great for stretch wrapping unstable pallet loads that are either too light or too heavy to rotate on a turntable wrapper. It wraps faster than a conventional turntable system and gives you flexibility to load the wrap zone with either a fork truck or pallet jack. The material handler sets the pallet on the floor in front of the wrapper and activates the wrapping cycle from a remote lanyard.

The EWA-SERIES® completes the job with the film carriage revolving around the stationary pallet load. Upon completion of the cycle, the system automatically clamps, cuts and wipes the film to the pallet. A safety sensor is included for instant stopping of the rotating film carriage arm. A robust swing arm drive system uses a slewing bearing design that ensures long life with minimal maintenance.

The EWA-SERIES® is manufactured in the USA in accordance with ARPAC's Lean Manufacturing Process (AM²) to ensure quality, performance and value. The wrapper is sold and serviced through our nationwide distributor network.



User-Friendly Operator Controls



Heavy Duty Slewing Bearing
and NEMA 3R Commutator



Electric Clamp, Cut and Wipe Down System

FEATURES

- Heavy-duty reinforced structural steel construction for around-the-clock operation
- Baked on powder coat finish provides a durable scratch resistant surface and prevents corrosion
- Allen-Bradley® Micrologix PLC
- An automatic machine that requires no air source
- No air = energy saver!
- Electric clamp, cut and wipe down system
- NEMA 12 electrical panel
- NEMA 3R commutator – conducting electricity between rotating arms and fixed frame allows for an enhanced trouble-free, longer life (dust and moisture proof)
- Rotary arm has a dual belt drive
- Main drive gear box is maintenance free
- Heavy duty slewing bearing to support rotary tower
- Setup is quick and easy!
- User-friendly operator controls
- Built in self-diagnostics
- Positive home position alignment
- Top over-wrap and cycle pause control
- Electronic film tension adjustment control
- Carriage pause control (banding)
- Adjustable top and bottom wrap counters (0-7)
- Photo electric load height sensor that detects most dark-colored loads
- Safety sensor stops arm rotation in emergencies
- Flashing safety light warns that machine is in operation
- Variable arm speed (0-15RPM)
- Variable carriage speed (0-24FPM)
- EZ-LOAD FILM-SAVR® Powered Pre-Stretch 150%-300% (200% standard)
- Wraps down to 3" from the floor
- Anti-static rollers
- UL approved components
- Lifetime warranty on ARPAC pre-stretch rollers
- Tower wrap height up to 80"
- Remote lanyard

SPECIFICATIONS

Power Requirements

- Electrical: 120V, 1Ph, 60Hz, 20A, 2.4kW
- NEMA 12 electrical panel

Load Sizes

- Max. Load Size: 53"L x 53"W x 80"H
- Wrap Diameter Clearance: 75"
- Max. Load Weight: dependent on floor capacity

OPTIONS

- Tower extensions up to 110" wrap height
- Arm extension for 85" wrap diameter
- Load Size: 60"L x 60"W x 110"H
- NEMA 4X controls
- All ARPACSTRETCH™ equipment can be custom designed to suit your specific application
- More options available, consult your local ARPACSTRETCH™ representative

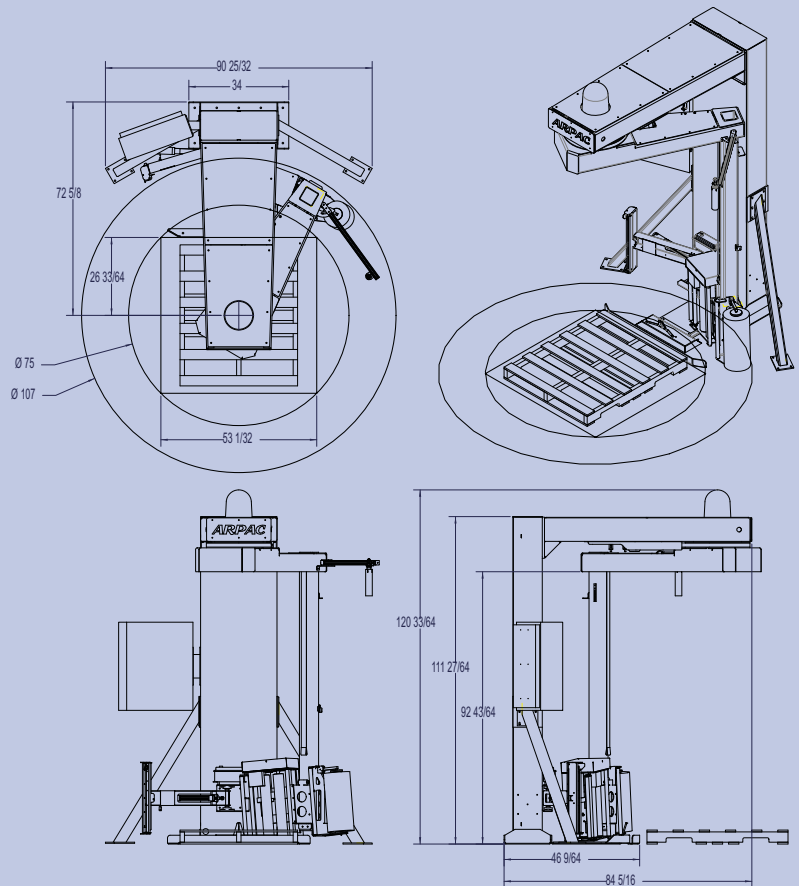

EWA-S5-71 Shown