



TRP-5/TRP-5C

Standard Features

Low-cost automation! Our standard TRP-5 and TRP-5C operate at speeds of up to 42 cycles per minute yielding a maximum of 30 bundles per minute contingent on package characteristics, machine size and accessories. The new High Speed Models (TRP-5 and TRP-5C) are capable of up to 56 cycles per minute, yielding approximately 40 bundles per minute.

- The standard TRP-5 equipped with a Belt Conveyor Table is suitable for strapping of totes, light-weight boxed items and bundles at an attractive price. The TRP5-C is the same model configured with Powered Roller Conveyor Table. It is an ideal machine for heavier products such as cut paper, roofing tiles, apple boxes, etc.

- **Sonixs Sealer®** features ultrasonic strap sealing which reduces mechanical motion and wear of moving parts for smooth operation at high speed. Innovative lever style gripper and knife design utilizing sealed bearing construction sheds dust and dirt, extending service intervals and reducing maintenance requirements.

- Energy saving and wear-free direct drive DC sealer.

- Compact 24" depth fits into most production lines; capable of upstream/downstream integration with material handling systems.

- System features a variable speed conveyor and adjustable strapping placement of one or two straps per package.

- The highly refined strapping head features automatic strap threading for fast coil loading; and quick, tool-less cleaning with snap-apart internal strap guides.

- The fully enclosed one-piece strap track provides positive strap delivery for exceptional feed reliability. Additional features include automatic strap loop ejection if the machine is cycled without a package in place. Automatic coil-end detection and ejection further enhance system reliability.

- Interlocked, hinged tabletop allows for fast, safe access to the sealer for cleaning or troubleshooting.

- End loading coil dispenser slides easily into coil change position and tucks into cabinet for safe operation.

- Uses lowest cost strapping available in widths of 5mm to 12mm. Simple, external controls adjust strap tension to meet varying package demands.

- Options include a double pneumatic compression device to help stabilize products during the strapping cycle; backstops; and signal lights for system faults or readiness. **New!** High Speed option includes upgraded Siemens PLC and faster sealer head motor.

Technical Data

Production Rate: 30 bundles maximum per minute (Approximately 40 with High Speed Option) depending on package characteristics, machine size and accessories.

Strap: 5mm, 6mm, 8mm, 9mm, and 12mm (1/2") Machine Grade Polypropylene

Track Sizes: 600 x 500 (23.6" x 19.7"); 800 x 600 (31.5" x 23.6"); 1000 x 800 (39.37" x 31.5") (w x h)

Electrical Requirements: 200-575V, 3 Phase

Strap Tension: DC Motor-Controlled, infinitely adjustable up to 80 Pounds

Strap Seal: Heat-Seal, Electronic Temperature Controlled, or Optional Sonixs Ultrasonic

Machine Color: Blue RAL 5010

Machine Shipping Weight: Approximately 900 - 1,100 Lbs. depending upon model.

Options:

- 3-Tier Light Tower for 'Ready', 'Trouble' and 'Low Strap' (not available with additional options.)
- Pneumatic Press (Air Requirements: 3 CFI @ 80 PSI)
- Backstops
- Low Frame with Outriggers
- 'Low Strap' Light Tower (available alone; with press; with backstops; or with both press and backstops.)
- Controls for automatic strapping of postal tubs and trays.
- Powered Roller Conveyor Table
- High Speed Package

Note: PLC capacity is limited. Not all option combinations are feasible.

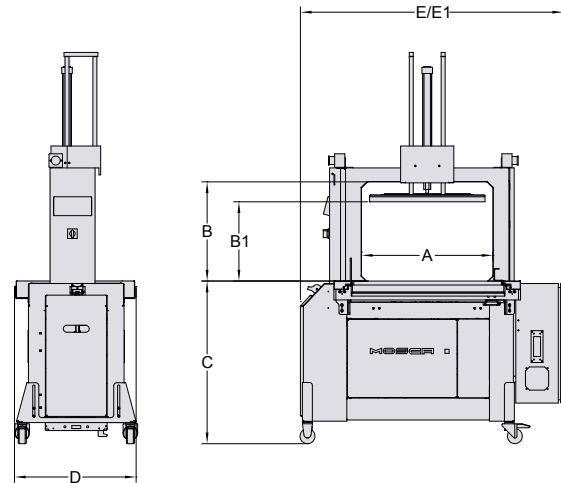

Model	A		B Without Press		B1 With Press		C*		D		E		E1**	
	Inches	mm	Inches	mm	Inches	mm	Inches	mm	Inches	mm	Inches	mm	Inches	mm
600	23.6"	600	19.7"	500	15.7"	400	32.25 - 36.5"	820 - 925	24"	610	52.4"	1330	74"	1880
800	31.52"	800	23.6"	600	19.7"	500	32.25 - 36.5"	820 - 925	24"	610	60.25"	1530	82"	2082
1000	39.37"	1000	31.50"	800	27.56"	700	32.25 - 36.5"	820 - 925	24"	610	68"	1730	89.76"	2278

*Low Frame Option with Outriggers: 29" - 33" (730 - 835mm)

** Measurement if strap coil drawer is fully opened.